

Unesco technical papers
in marine science 27

Collected reports of the joint panel
on oceanographic tables and standards,
1964-1969

sponsored by
Unesco, ICES, SCOR, IAPSO

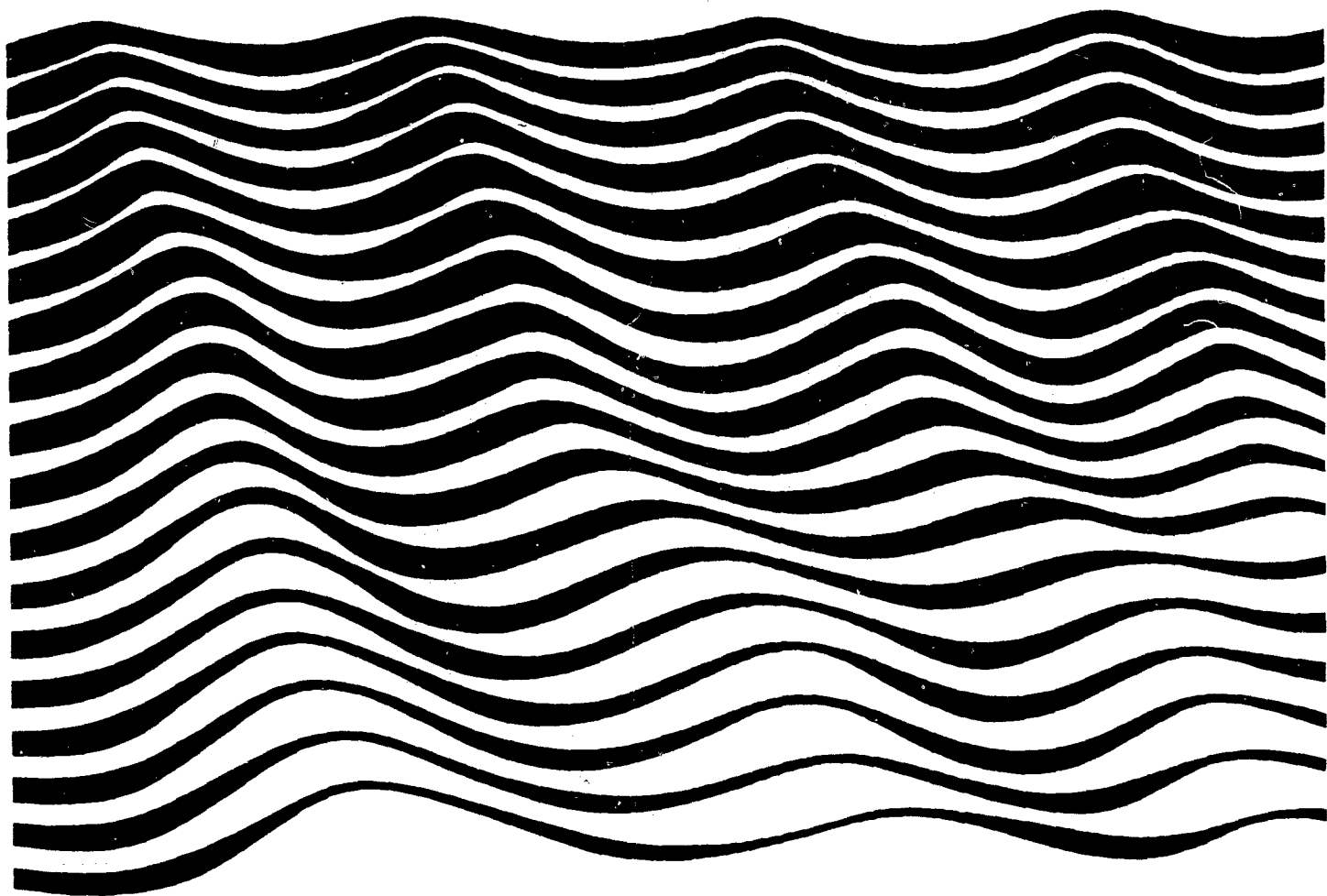

Unesco 1976

UNESCO TECHNICAL PAPERS IN MARINE SCIENCE

Numbers 2, 3, 5, 6, 7, 10 and 12 are out of stock. For full titles see inside back cover.
Numbers 1, 4, 8 and 14 are incorporated in No. 27.

No.		Year	SCOR WG
9	Report on intercalibration measurements, Leningrad, 24-28 May 1966 and Copenhagen, September 1966; organized by ICES	1969	—
11	An intercomparison of some current meters, report on an experiment at WHOI Mooring Site "D", 16-24 July 1967 by the working group on Continuous Current Velocity Measurements. Sponsored by SCOR, IAPSO and Unesco	1969	WG 21
13	Technical report of sea trials conducted by the working group on photo-synthetic radiant energy, Gulf of California, May 1968; sponsored by SCOR, IAPSO, Unesco	1969	WG 15
15	Monitoring life in the ocean; sponsored by SCOR, ACMRR, Unesco, IBP/PM	1973	WG 29
16	Sixth report of the joint panel on oceanographic tables and standards, Kiel, 24-26 January 1973; sponsored by Unesco, ICES, SCOR, IAPSO	1974	WG 10
17	An intercomparison of some current meters, report on an experiment of Research Vessel Akademik Kurchatov, March-April 1970, by the working group on Current Velocity Measurements; sponsored by SCOR, IAPSO, Unesco	1974	WG 21
18	A review of methods used for quantitative phytoplankton studies; sponsored by SCOR, Unesco	1974	WG 33
19	Marine Science Teaching at the University Level. Report of the Unesco Workshop on University Curricula — <i>Also published in French and Spanish</i>	1974	—
20	Ichthyoplankton. Report of the CICAR. Ichthyoplankton Workshop <i>Also published in Spanish</i>	1975	—
21	An intercomparison of open sea tidal pressure sensors. Report of SCOR Working Group 27: "Tides of the open sea"	1975	WG 27
22	European sub-regional co-operation in oceanography. Report of a working group sponsored by the Unesco Scientific Co-operation Bureau for Europe and the Division of Marine Sciences	1975	—
23	An intercomparison of some current meters, III. Report on an experiment carried out from the Research Vessel Atlantis II, August-September 1972, by the Working Group on Continuous Velocity Measurements: sponsored by SCOR, IAPSO and Unesco	1975	WG 21
24	Seventh report of the joint panel on oceanographic tables and standards, Grenoble, 2-5 September 1975; sponsored by Unesco, ICES, SCOR, IAPSO.	1976	WG 10
25	Marine science programme for the Red Sea: Recommendations of the workshop held in Bremerhaven, FRG, 22-23 October 1974; sponsored by the Deutsche Forschungsgemeinschaft and Unesco	1976	—
26	Marine sciences in the Gulf area - Report of a consultative meeting, Paris, 11-14 November 1975	1976	—
27	Collected reports of the joint panel on oceanographic tables and standards, 1964-1969	1976	WG 10

**Unesco technical papers
in marine science
no. 1**

First report of the joint panel on oceanographic tables and standards

**held at Copenhagen
5-6 October 1964**

**sponsored by
UNESCO, ICES, SCOR, IAPO**

Unesco

FIRST REPORT OF THE JOINT PANEL ON
OCEANOGRAPHIC TABLES AND STANDARDS

held at
Copenhagen, 5-6 October, 1964

jointly sponsored by the

United Nations Educational, Scientific and Cultural Organization
International Council for the Exploration of the Sea
Scientific Committee on Oceanic Research
International Association of Physical Oceanography

1965

The scientific views expressed here are those of experts participating in the work of the Panel and not necessarily those of Unesco or other sponsoring organizations.

NS.65.XV.1.A

This report concerns a meeting held at Charlottenlund Slot, Denmark, on 5/6 October, 1964. The meeting was sponsored jointly by the Hydrographical Committee of ICES and Unesco, and was convened by Dr. R.A. Cox who took the Chair. Present were:

1. Members of the joint IAPO/SCOR/ICES/UNESCO panel on oceanographic tables and standards:

D.E. Carritt (U.S.A.)
R.A. Cox (U.K.)
N.P. Fofonoff (U.S.A.)
F. Hermann (Denmark)
Y. Miyaki (Japan)
O. Saelen (Norway)

Apologies for absence were received from G. Dietrich (Germany) and G.N. Ivanoff-Frantzkevich (U.S.S.R.)

2. Participants in the meeting, in addition to the members of the panel included:

Argentina	-	A. Orlando
Denmark	-	S.F. Larsen, J. Smed
Finland	-	I. Hela, A. Voinio, F. Koroleff
Germany	-	K. Grasshof, G. Weichart
Iceland	-	S.A. Malmberg
Netherlands	-	R. DoFrestein
Norway	-	J. Eggvin, E. Fjøl
Spain	-	N. Menendez
Sweden	-	B. Kullenberg, A. Svansson, S.H. Fonselius
U.K.	-	F. Culkin, D.P.D. Scott
UNESCO	-	K.N. Fedorov
U.S.A.	-	J. Lyman

First Session, Monday morning

In his introduction, the chairman, Dr. R.A. Cox, referred to the first and second reports of the joint panel on the equation of state of sea water and explained that on the disbanding of this committee in Berkeley in August, 1963, the members, with the addition of Dr. O. Saelen, were designated the joint panel on oceanographic tables and standards. He listed certain problems which would be considered by the meeting. Following is a summary of the chairman's remarks, as distributed before the meeting:-

The "Equation of State" of Sea Water

The "equation of state" of sea water is the mathematical expression to calculate density from measurements of temperature, pressure and salinity, or from other parameters dependent on these. In its most usual form the equation is expressed with density or specific volume as a function of temperature, pressure and salinity. Salinity, however, can be replaced by any of a large range of measured properties such as conductivity, refractive index or sound velocity. All these properties, however, are themselves dependent on both temperature and pressure; computing the density from temperature, pressure and conductivity, for example, is more difficult than from salinity,

Virtually all the computations of density of sea water made during the last 60 years have been based on measurements of density, chlorinity and salinity by Forch, Knudsen and Sørensen, published in 1902, and of compression by Amagat in 1893 and Ekman in 1908. All these measurements were of very high quality, and even today it is unlikely that we can greatly improve on them. However, there are several aspects of the problem which have recently attracted considerable attention, and it is now certain that we do not know enough about the basic relationships; in consequence the full precision of modern techniques of measurement cannot be used.

Among the points where we need further knowledge are these

1. "Density". We refer our densities as ratios to the density of "pure water, but nobody has defined the pure water. Density of water varies according to the source, e.g., rain water is lighter than distilled sea water.
2. "Absolute density". Physical oceanographers take specific gravity measurements, take the reciprocal (specific volume) and give it units of cm^3/ρ . This is quite wrong, and we do not know the conversion factor to make it right.
3. Nobody has measured salinity for 60 years. At present chlorinity, conductivity and refractive index measurements are all being converted to "salinity" by inadequate tables of often doubtful origin. All make assumptions regarding constancy of relative proportions of the various ions, which are doubtful and may be quite unjustified, to the precision of our modern measurements.

The "Standard sea water programme" at the National Institute of Oceanography has been run to try and answer some of these problems; similar work is underway in several laboratories. Among other subjects for discussion at this meeting will be the present state of this work; and the future prospects.

In addition delegates will no doubt wish to discuss the recommendations of the joint ICES/SCOR/IAPO/UNESCO committee on the equation of state of sea water, and in particular how those recommendations may need modification from recent work. The members of the Committee are anxious that discussion and criticism should be as general as possible.

We hope that, at this meeting, the delegates will be able to describe other work in progress, or projected, in this difficult but important field.

Another matter which should be discussed is the intention of the International Bureau of Weights and Measures to re-define the litre as a cubic decimetre. This has a bearing on oceanographic units, and it may be that this meeting will wish to make representations to the International Bureau on the subject.

The Standard Sea Water Service is intending to distribute standard sea water as soon as is practicable, certified in conductivity as well as, or as an alternative to, chlorinity. There are serious difficulties to be overcome before this can be done, and it may well be helpful to discuss these difficulties.

The meeting then discussed certain details of the first and second reports. Most important was the problem of the definition of salinity. The chairman referred to discussions between Dr. Saalen and himself on the problems of an absolute standard of density; these discussions led to the conclusion that it would be preferable to use conductivity as the reference parameter, since this would shortly be determinable in absolute terms. Moreover, it was intended that the standard sea water would then be calibrated in conductivity.

The N.I.O. had about 400 determinations of conductivity and chlorinity on natural sea water samples. A regression equation had been computed from these connecting chlorinity (or salinity defined as $S‰ = 1.80655 \text{ cl } ‰$) with conductivity ratio, defined as the ratio of the conductivity to that of standard sea water batch P 31, chlorinity 19.374, both samples being at 15°C . Equations had been computed from these values up to the sixth order, but it was found that beyond the second order there was no significant improvement in fit to the data. The quadratic equation was hence used to compute a table connecting relative conductivity with salinity. A sheet from this table, covering the salinity range 34.91 - 35.11 was distributed to the meeting, and is included with this report. (Appendix A).

This equation could serve as the definition of salinity. However, there was a difficulty. Most of the samples with a salinity of about 35‰ were deep samples; many of these contained more calcium than surface water and hence had a fractionally higher conductivity than standard sea water, which is Atlantic surface water. Thus a conductivity ratio of 1.0 did not correspond to a salinity of 35‰, but with 34.994‰. This was a perfectly correct result, and reflected the fact that the standard water was not quite average. However, this result was potentially confusing, and would mean that Atlantic deep salinities, for example, computed from the new tables would not exactly correspond with older figures.

Various ways of resolving this discrepancy were discussed. These included:

1. Using deep water for preparing future standard sea water
2. Increasing the conductivity of the standard by adding, for example, sodium sulphate
3. Displacing the equation by adding a constant
4. Computing a new equation, using surface observations only
5. As 4, but if necessary adding a constant to the equation to make ratio 1.0 exactly correspond to salinity 35‰.

After a long discussion, the fifth course of action was adopted. The computing of the new equation, using surface observations only, is at present underway at the N.I.O. This equation will serve as the definition of salinity; at the moment it will be available only in terms of relative conductivity, but shortly it will be possible to give the definition also in terms of the ohm and centimetre. This salinity, so defined, will correspond with the chlorinity of surface sea water as nearly as is permitted by the natural scatter of the relationship. However, to compute the most probable chlorinity of a deep oceanic water from this salinity, a small depth correction will be necessary, reflecting the different average composition of deep water.

The next step will be to relate this salinity to density. The chairman explained that all we can do at the moment is to relate salinity to specific gravity; that is a ratio of density to the density of a defined pure water at 4°C. The intention was to prepare such a pure water by distillation of sea water. There was considerable discussion on the best location from which to take the water, but it was finally agreed that water from 2000 m down in the western basin of the Mediterranean Sea would be as good as any; several speakers emphasized that the distillation procedure should be defined as closely as possible, and the water so prepared should be characterised by isotopic analysis.

There was also general agreement that comparisons should be made with water from various sources, to see if significant variations in density were apparent.

To compute density in absolute units, in g/cm^3 , the absolute density of the reference water must be determined. This determination is beyond the resources of the N.I.O., but the chairman reported that the National Physical Laboratory in England would be prepared to undertake this determination if the necessary funds were available. The order of cost was estimated at £31,000 (\$100,000).

The meeting decided to write to the Bureau International des Poids et Mesures, asking their support in this work. A copy of the letter and that of the answer are appended. (Appendix B).

Mr. Hermann, on behalf of the Standard Sea-Water Service, reported that several requests had been received for standard water with high and low salinities, in addition to the normal 35‰. The meeting felt that there was no point in such alternative standards for chlorinity determination, and little point for low-range conductivity measurements because of the wide natural scatter usually found at low salinities. In the special case of the Mediterranean, however, there might be a call for a conductivity standard with a salinity of about 38.5‰. The use of such a standard should lead to a significant improvement in precision by greatly reducing transfer errors.

When the new conductivity apparatus is working a high-salinity standard could be prepared on the same basis as the present standard, given a supply of suitable water. Dr. Fedorov undertook to raise the matter at the forthcoming meeting of Mediterranean oceanographers, in Monaco.

Second Session, Monday afternoon

The chairman gave the meeting a description of the apparatus for determination of absolute conductivity, which is at present under construction at the N.I.O. It is hoped to start trials with this apparatus within the next month, and if the first results are satisfactory, to have the apparatus complete early next year.

The apparatus involves a fused silica cell of known physical dimensions, in which are mounted two platinum electrodes, one fixed and the other movable. The cell contains the solution under test in a thermostat at $15^{\circ}\text{C} \pm 0.0005^{\circ}\text{C}$. A transformer bridge compares the resistance of the solution with that of a standard resistor. The movable electrode is then moved a known distance, and the resistance again measured. The change in resistance should be independent of electrode effects, and a true measure of conductivity in absolute units.

The intention was firstly to use this apparatus to measure the absolute conductivity of standard water P 31 at 15°C. Measurements would also be made at 15°C and 25°C on other sea waters and sodium and potassium chloride solutions. These measurements should take only a few weeks, after which the apparatus would be available for the calibration of the standard sea water in conductivity, and for such studies as the change in conductivity with time under various storage conditions.

Mr. Hermann raised the question of maintenance of the apparatus, pointing out that the Standard Sea Water Service had no access to skilled electronic maintenance staff. He suggested it would be better that the apparatus be kept at the N.I.O., where such help was available. The chairman said the apparatus was being designed and built to reduce maintenance to a minimum, and in case of major difficulties the N.I.O. staff would be able to help. It was decided, on the chairman's suggestion, that Mr. Hermann should visit the N.I.O. during the final tests and measurements with the apparatus, and that the question of the final location of the apparatus should then be agreed between Mr. Hermann and Dr. Cox, who should then ask the committee to approve their decision.

The chairman gave a brief account of measurements of refractive index, which were underway at N.I.O. A Jamin interferometer had been borrowed from Oxford University, and was giving good results. It seemed that with a 10 cm path length it would be possible to determine differences in refractive index to a few units in the 7th decimal, which would compare well with the precision of conductivity salinometers. The determination of absolute refractive index was far more difficult, and probably not possible to this precision; this difficulty did not, however, affect the use of the method for salinity determination, using standard sea water as reference. Tables would be issued relating salinity to refractive index anomaly, using standard water as reference. The N.I.O. were using mercury green light (Wratten filter 77A, 5461A⁰). Dr. Rusby has found it necessary to use a low-power lamp and define the conditions, as high-power light sources cause frequency drift as they warm up. Basic measurements are to be at 20⁰, with certain additional measurements to see how much refractive index anomaly changed with temperature.

Third Session - Tuesday morning

The session started with the presentation of two papers:

1. Paper No.139. The bromide/chlorinity ratio of Baltic Waters, by F. Koroleff.
2. The sulphate content of Baltic Water and its relation to the chlorinity, by B. Kwiecinski, presented by S.H. Fonselius.

The discussion on these interesting papers raised the important question of the unique composition of Baltic Water. The chairman could not promise that the relationships computed at the N.I.O. would be valid for the Baltic; so far, only samples within the salinity range 30 - 42‰ had been used for the computations. It might prove necessary to employ special tables for such areas. If the Baltic observations were included, all the evidence suggested that zero chlorinity and zero salinity would not agree. This disagreement presented problems when considering the dilution of sea water by pure water, such as rain or snow; it was not possible to provide a table applicable to both situations.

The committee undertook to bear in mind the special problem of the Baltic oceanographers, and to cooperate with them in the preparation of such tables as are appropriate for this important region.

The chairman and Dr. Culkin described certain problems which had arisen in the determination of chlorinity in the N.I.O. programme. Mr. Hermann had repeated a small number of chlorinities, and his results confirmed the suspicions of the N.I.O. that there were a few erroneous results in the series. In view of the importance attached to these results, and to our understanding of the causes of variations in chlorinity/conductivity ratio, it has been decided to repeat all the chlorinity determinations, also repeating the conductivity ratio on the same tube of water.

This work is to be shared between Liverpool University and N.I.O., and has already started. Of some 30 results so far available at N.I.O., the original chlorinity was confirmed within $\pm 0.002\%$ in most cases, but in some 4 samples the new value was significantly nearer that computed from conductivity. On these 30 results alone, the root mean square deviation between each chlorinity and the mean line has been reduced from about 0.012‰ to 0.008‰. Mr. Crease, who was superintending the computer work on the results, thought the effect of these new values on the existing conductivity/chlorinity line would be quite negligible; however, by eliminating the small proportion of errors, the fit to the chemical analysis should be greatly improved.

The present chlorinity determinations are being made by Dr. Culkin and Dr. Orlando, at N.I.O., using a weight burette/volumetric method. An endpoint meter designed by Dr. Cox was used, in which dichloro-fluorescein indicator caused a colour change observed by a photo-electric system. This system was reliable, but unfortunately not quite sensitive enough to judge the endpoint to within 0.001‰. Mr. Hermann strongly advocated a change to the electrode system which he favoured, where the reference electrode was a silver wire inside the burette jet, the tip of which was in the titrated solution. In discussion, several members agreed that this system was more reliable than the mercurous sulphate reference electrode favoured by Dr. Riley. Mr. Hermann offered to make a set of electrodes for the N.I.O., which offer was gratefully accepted.

Fourth Session, Tuesday afternoon

The agenda for this final session covered the details and distribution of new oceanographic tables. The chairman opened the discussion by presenting the sample sheet of tables, in this case relating relative conductivity to salinity (Appendix A). Members of the committee had discussed details with Dr. Fedorov, and proposed that:

1. The tables be issued as single sheets, suitable for binding in a loose-leaf file, as this would facilitate addition of further sheets as these became available, or replacement if necessary.
2. The sheet size should be 27 x 21 cm (10½ x 8 ins.).
3. When tables were prepared by computer, a direct photographic reproduction of the print-out should be used, to avoid type-setting errors.
4. The Office of Oceanography, UNESCO, would be responsible for publication and distribution of the tables.

A general discussion followed. The presentation and layout of the sample sheet received general approval, the chairman pointing out that to correspond with the proposed sheet size, a reduction of about 15% in the size of the computer's print-out would be necessary. The sheet which is given in Appendix A is somewhat smaller than the size proposed in (2) above. Besides, as follows from page 5, this sheet will have to be re-calculated. The issue of single sheets was criticised because of their tendency to tear. Lt. Cdr. Scott suggested it would be better to issue each table as a booklet, without stiff covers, and suitable for binding with others in a file cover. Others emphasized that whatever binding was adopted, the pages must open and lie flat when in use. Single sheets might be better if suitably reinforced. Dr. Fedorov undertook to consult with the UNESCO publishing department on these matters:

Dr. Fedorov agreed that it would be appropriate to provide each oceanographic institution with one free copy of the Tables. This would be a valuable step towards securing their general adoption. All additional copies would have to be paid for either through a system of subscription or by making it possible to purchase individual tables or sheets as replacements or for special purposes.

It was agreed that the conductivity ratio/salinity table at 15° should be distributed first, as it was urgently wanted to resolve problems of salinometer calibration. This should be available within a few weeks. Professor Kullenberg thought that expense could be reduced by printing one less decimal of conductivity, with an interpolation table for the last place; however, several users of salinometers disagreed strongly,

and it was decided to proceed with the full table. There was discussion on the use of such a table with non-thermostat salinometers, such as the Auto-lab and Hytech instruments, for which the present tables are computed to be correct at 22.5°. The chairman said there would be no difficulty in computing tables of conductivity ratio to salinity applicable to any desired temperature. However, it was doubtful if this was strictly necessary. Whatever tables were used with a non-thermostat meter, second-order corrections would be necessary if the samples varied much in temperature, unless the salinity was very close to 35‰. These corrections were, however, minimized by computing the table for the mean working temperature. 22.5° was too high for most European laboratories, but was a compromise between temperate and tropical ranges. The 15° tables were perfectly valid for use with such salinometers, providing the appropriate corrections were made for operating temperature, and a suitable correction table would be computed. The corrections would, however, be about four times greater when working at 25° than with the present tables. Some workers in warm regions had found that they could legitimately disregard these small corrections, but with a 15° table this might no longer be possible. If there was a sufficient demand for a "tropical" table, the committee would consider providing it.

Probably the next most important tables are those for computing density. The meeting favoured a table for computing σ_t (specific gravity anomaly) from temperature and salinity. The form of this table, and of tables for specific volume anomaly, was not decided; it was suggested that sample sheets of existing tables should be circulated, and comments requested from oceanographers. A selection of such sample sheets is appended (Appendix C).

Tables so far suggested for the series are listed below:

- 1a. Conductivity ratio/salinity at 15°.
- 1b. Conductivity ratio, variation with temperature and salinity.
- 1c. Conductivity variation with pressure (depth).
- 2a. Specific gravity anomaly (σ_t) from T and S.
- 2b. Specific volume anomaly variation with pressure.

(The details of group 2 to be decided after further discussion).

- 3a. Refractive index anomaly at 20°, 5461A°, to salinity.
- 3b. Refractive index anomaly, variation with temperature and salinity.
4. Velocity of sound, from T, S, P.
5. Adiabatic expansion correction, for insulated water bottles.
6. Potential temperature, from T, P, S.
7. Specific heat, from T, S.

The Committee would welcome suggestions for additions or modifications to this list, as well as suggestions on the most convenient format of the various tables, in particular the specific gravity and specific volume tables. Suggestions can be sent to any member of the Committee, or to the Director, Office of Oceanography, UNESCO. As work on the tables will start very soon, suggestions should be made as early as possible.

Prepared by
Roland A. Cox.

Appendix A. Sample sheet of proposed new tables.

Relative Conductivity — Salinity 34.91–35.11 ‰

		0	1	2	3	4	5	6	7	8	9
0.99	80	34.915	916	916	917	917	917	918	918	919	919
	81	919	920	920	921	921	921	922	922	922	923
	82	923	924	924	924	925	925	926	926	926	927
	83	927	928	928	928	929	929	930	930	930	931
	84	931	932	932	932	933	933	933	934	934	935
	85	935	935	936	936	937	937	937	938	938	939
	86	939	939	940	940	941	941	941	942	942	942
	87	943	943	944	944	944	945	945	946	946	946
	88	947	947	948	948	948	949	949	950	950	950
	89	951	951	951	952	952	953	953	953	954	954
0.99	90	955	955	955	956	956	957	957	957	958	958
	91	959	959	959	960	960	961	961	961	962	962
	92	962	963	963	964	964	964	965	965	966	966
	93	966	967	967	968	968	968	969	969	970	970
	94	970	971	971	971	972	972	973	973	973	974
	95	974	975	975	975	976	976	977	977	977	978
	96	978	979	979	979	980	980	981	981	981	982
	97	982	982	983	983	984	984	984	985	985	986
	98	986	986	987	987	988	988	988	989	989	990
	99	990	990	991	991	991	992	992	993	993	993
1.00	00	994	994	995	995	995	996	996	997	997	997
	01	998	998	999	999	999	000	000	001	001	001
	02	35.002	002	002	003	003	004	004	004	005	005
	03	006	006	006	007	007	008	008	008	009	009
	04	010	010	010	011	011	011	012	012	013	013
	05	013	014	014	015	015	015	016	016	017	017
	06	017	018	018	019	019	019	020	020	021	021
	07	021	022	022	022	023	023	024	024	024	025
	08	025	026	026	026	027	027	028	028	028	029
	09	029	030	030	030	031	031	031	032	032	033
1.00	10	033	033	034	034	035	035	035	036	036	037
	11	037	037	038	038	039	039	039	040	040	041
	12	041	041	042	042	042	043	043	044	044	044
	13	045	045	046	046	046	047	047	048	048	048
	14	049	049	050	050	050	051	051	051	052	052
	15	053	053	053	054	054	055	055	055	056	056
	16	057	057	057	058	058	059	059	059	060	060
	17	061	061	061	062	062	062	063	063	064	064
	18	064	065	065	066	066	066	067	067	068	068
	19	068	069	069	070	070	070	071	071	072	072
1.00	20	072	073	073	073	074	074	075	075	075	076
	21	076	077	077	077	078	078	079	079	079	080
	22	080	081	081	081	082	082	082	083	083	084
	23	084	084	085	085	086	086	086	087	087	088
	24	088	088	089	089	090	090	090	091	091	092
	25	092	092	093	093	093	094	094	095	095	095
	26	096	096	097	097	097	098	098	099	099	099
	27	100	100	101	101	101	102	102	102	103	103
	28	104	104	104	105	105	106	106	106	107	107
	29	108	108	108	109	109	110	110	110	111	111

Appendix B

Copy of letter from the Committee on Oceanographic Tables and Standards to the International Bureau of Weights and Measures, and of the reply received from the Director of the Bureau.

"

AVS/9/114B

8 October 1964

Dear Sir,

The joint committee of experts on oceanographic tables and standards (which is appointed jointly by UNESCO, ICES, SCOR and IAPO)* has been considering the problems inherent in the determination of the density of sea water. This is normally computed from measurements of temperature, salinity and pressure, and is today commonly reported to a precision of 1 in 10^6 .

The oceanographic tables are based on measurements of specific gravity referred to an undefined "pure water". As you are, of course, aware, the density of pure water varies somewhat, depending on its isotopic composition, which varies both with source and treatment.

Oceanographers would like to report their density values in terms of the gram and centimetre and I am sure the Bureau would wish us to do this. Before this can be done, however, we would need reference water of known density. In order that this standard could be reproduced, its isotopic composition should also be defined.

We should be grateful if the Bureau would advise us on any work, either in progress or contemplated, which would assist us in this aim. This Committee would be happy to cooperate with any international or national organisation which is working in this field.

./..

Mr. Jean Terrien
Director,
International Bureau of Weights & Measures
Pavillon de Breteuil
SEVRES (Seine et Oise)

- * ICES = International Council for the Exploration of the Sea
- SCOR = Scientific Committee on Oceanic Research
- IAPO = International Association of Physical Oceanography

Dr. Fedorov, Director of the Office of Oceanography, Unesco, would be happy to provide further information on our problems, should the Bureau so wish, and could serve as a liaison between the Bureau and our Committee.

On behalf of the Committee,

(Sgd.) K.N. Fedorov
Director

Office of Oceanography, Unesco

cc: Prof. D.E. Carritt, IAPO
Dr. R.A. Cox, ICES
Prof. Dr. G. Dietrich, SCOR
Dr. N.P. Fofonoff, IAPO
Dr. G.N. Ivanov-Frantzkevich, UNESCO
Dr. Y. Miyake, SCOR
Dr. F. Hermann, ICES
Dr. O. Saelen, ICES

n

BUREAU INTERNATIONAL
DES
POIDS & MESURES

Jb/Co

Pavillon de Breteuil
Sèvres (S. & O.) France

21 octobre 1964

Monsieur K.N. Fedorov
Directeur
Bureau d'Océanographie
U.N.E.S.C.O.
Place de Fontenoy
PARIS (7e)

Monsieur,

Nous avons pris connaissance de votre lettre
AVS/9/114B du 8 octobre 1964, relative à la masse volumique
de l'eau de mer.

La détermination préalable de la masse volumique
d'une eau pure de composition isotopique connue n'a pas été
faite et n'est pas en cours ni au Bureau International des
Poids et Mesures, ni ailleurs à notre connaissance. Si une
étude aussi importante était entreprise par un organisme
possédant tout ou partie des moyens nécessaires, il est
possible que le Comité International des Poids et Mesures
autorise l'exécution totale ou partielle des travaux au
B.I.P.M.

Je vous signale, pour le cas où vous ne le sauriez pas,
que Mr. MENACHE, à l'Institut Océanographique (MED 34-46),
s'est déjà beaucoup occupé de questions analogues.

Veuillez agréer, Monsieur, l'expression de ma
considération distinguée.

Le Directeur

(Signé) J. Terrien

"

SAMPLES OF TABLES FOR SPECIFIC GRAVITY AND SPECIFIC VOLUME

Following are sample sheets from seven sets of tables for deriving σ_t from salinity and temperature, in some cases through an intermediate stage of σ_0 or $\rho_{17.5}$. There is also one example of a reverse table (salinity from σ_t) and three samples of specific volume tables from salinity temperature and pressure.

We would like potential users of such tables to consider seriously which type of tables they would prefer, and if appropriate suggest compromises or modifications of the format given here.

In the headings to each sample an estimate is given of the number of sheets of figures which would be needed to cover the salinity range 30 to 42^o/₀₀. This does not necessarily imply that we should not include tables for lower or higher salinities, but this is the range of greatest interest to most oceanographers, and initially it is proposed to concentrate on this range.

Comments or suggestions regarding these or other tables should be sent to any member of the committee on oceanographic tables and standards, or to the Office of Oceanography, UNESCO.

The Editors apologise for the rather poor quality of reproduction of the sample tables in this annex as double copying was involved in its process. The Editors hope, however, that it will not create inconvenience since these sample tables are not meant for actual use.

Knudsen's hydrographical tables. Two stages, salinity to sigma-0, sigma-0 and temperature to sigma-t.

8 sheets + 4 sheets

<i>Cl</i>	<i>S</i>	‰	<i>P17.5</i>	<i>Cl</i>	<i>S</i>	‰	<i>P17.5</i>
19.00	34.33	27.58	26.22	19.50	35.23	28.31	26.91
.01	.34	.60	.23	.51	.25	.32	.92
.02	.36	.61	.24	.52	.26	.34	.94
?	.38	.63	.26	.53	.28	.35	.95
	.40	.64	.27	.54	.30	.37	.96
	.42	.65	.29	.55	.32	.38	.98
	.43	.67	.30	.56	.34	.40	.99
	.45	.68	.31	.57	.35	.41	27.01
		.70	.33	.58	.37	.43	.02
		.71	.34	.59	.39	.44	.03
		7.73	26.36	19.60	35.41	28.46	27.05
			.37	.61	.43	.47	.06
			.38	.62	.44	.48	.07
			.40	.63	.46	.50	.09
			.41	.64	.48	.51	.10
			.42	.65	.50	.53	.12
				.66	.52	.54	.13
				.67	.53	.56	.14
				.68	.55	.57	.16
				.69	.57	.59	.17
					35.59	28.60	27.19
					.61	.62	.20
					.62	.63	.21
					.64	.64	.23
					.66	.66	.24
					.67	.67	.25
					.69	.69	.27
					.70	.70	.28
					.72	.72	.30
					.73	.73	.31
							27.32
							.34
							.35
							.36
							0.
							05
5°	007	007	007	007	008	008	008
6°	13	13	13	13	14	14	14
7°	20	20	20	20	21	21	21
8°	28	28	29	29	30	30	30
9°	38	38	39	39	40	40	40

$$\sigma_t = \sigma_0 - D$$

<i>t</i>	σ_0 =9.00	σ_0 =9.10	σ_0 =9.20	σ_0 =9.30	σ_0 =9.40	σ_0 =9.50	σ_0 =9.60	σ_0 =9.70	σ_0 =9.80	σ_0 =9.90	σ_0 =10.0	<i>D</i>	<i>t</i>	<i>t</i>	<i>t</i>	
-2°	0.09	0.08	0.08	0.08	0.08	0.08	0.08	0.08	0.08	0.08	0.08	0.08	0.08	0.08	0.08	0.08
-1°	03	03	03	03	03	03	03	03	03	03	03	03	03	03	03	03
0°	0.00	0.00	0.00	0.00	0.00	0.00	0.00	0.00	0.00	0.00	0.00	0.00	0.00	0.00	0.00	0.00
1°	02	02	02	02	02	02	01	01	01	01	01	01	01	01	01	01
2°	02	02	02	02	02	01	01	01	01	01	01	01	01	01	01	01
3°	01	00	00	00	00	00	00	00	00	01	01	01	01	01	01	01
4°	02	03	03	03	03	03	03	04	04	04	04	04	04	04	04	04
5°	007	007	007	007	008	008	008	008	008	009	009	009	009	009	009	009
6°	13	13	13	13	13	14	14	14	14	15	15	15	15	15	15	15
7°	20	20	20	20	21	21	21	22	22	22	22	23	23	23	23	23
8°	28	28	29	29	29	30	30	30	31	31	31	31	31	31	32	32
9°	38	38	39	39	39	40	40	40	41	41	41	41	42	42	42	43

Zhubov & Czihirin. Oceanological Tables. Moscow, 1940

Salinity to rho-17.5. (see last sheet- identical with Knudsen's tables)

Rho-17.5 and temperature to sigma-t.

8 sheets + 17 sheets.

T. 10. Correction E for the conditional density

$$\sigma_t = \rho_{17.5} - E$$

t° P17.5	20.0	20.2	20.4	20.6	20.8	21.0	21.2	21.4	21.6	21.8	22.0
0.00	1.77	1.83	1.87	1.91	1.94	1.99	2.02	2.07	2.11	2.16	2.20
1.00	.78	.83	.87	.91	.95	.99	.04	.08	.13	.17	.22
2.00	.79	.83	.87	.92	.96	2.00	.05	.09	.14	.18	.23
3.00	.79	.84	.88	.92	.97	.01	.06	.10	.15	.20	.24
4.00	.80	.85	.89	.93	.98	.02	.07	.11	.16	.21	.25
5.00	.81	.85	.90	.94	.99	.03	.08	.13	.17	.22	.26
6.00	.82	.86	.91	.95	2.00	.04	.09	.14	.18	.23	.28
7.00	.82	.87	.92	.96	.01	.05	.10	.15	.19	.24	.29
8.00	.83	.88	.92	.97	.01	.06	.11	.16	.20	.25	.30
9.00	.84	.88	.93	.98	.02	.07	.12	.16	.21	.26	.31
10.00	1.84	1.89	1.94	1.99	2.03	2.08	2.13	2.17	2.22	2.27	2.32
11.00	.85	.90	.95	.99	.04	.09	.13	.18	.23	.28	.33
12.00	.86	.90	.95	2.00	.05	.09	.14	.19	.24	.29	.34
13.00	.86	.91	.96	.01	.06	.10	.15	.20	.25	.30	.35
14.00	.87	.92	.97	.01	.06	.11	.16	.21	.26	.31	.36
15.00	.88	.93	.97	.02	.07	.12	.17	.22	.27	.32	.37
16.00	.88	.93	.98	.03	.08	.13	.18	.23	.28	.33	.38
17.00	.89	.94	.99	.04	.09	.14	.19	.24	.29	.34	.39
18.00	.89	.94	.99	.04	.09	.15	.20	.25	.30	.35	.40
19.00	.90	.95	2.00	.05	.10	.15	.21	.26	.31	.36	.42
20.00	1.91	1.96	2.01	2.06	2.11	2.16	2.21	2.27	2.32	2.37	2.43
21.00	.91	.97	.02	.07	.12	.17	.22	.28	.33	.38	.44
22.00	.92	.97	.02	.07	.12	.18	.23	.29	.34	.39	.45
23.00	.93	.98	.03	.08	.13	.19	.24	.29	.35	.40	.46
24.00	.93	.99	.04	.09	.14	.20	.25	.30	.36	.41	.47
25.00	.94	.99	.05	.10	.15	.20	.26	.31	.37	.42	.48
26.00	.95	2.00	.05	.11	.16	.21	.27	.32	.38	.43	.49
27.00	.95	.01	.06	.12	.17	.22	.28	.33	.39	.44	.50
28.00	.96	.02	.07	.12	.18	.23	.29	.34	.40	.45	.51
29.00	.97	.02	.08	.13	.19	.24	.30	.35	.41	.46	.52

United States Hydrographic Office publication 619

Temperature plus a linear correction from salinity to σ_t . Precision limited to about 0.02. 6 sheets

Thus: Given 15.70°C and 36.47‰ S.

From table for Salinity 30.00 to 39.99‰, enter column one at lower limit of temperature interval (15.69)

$$\begin{array}{r} \text{obtain base} \\ \text{value in} \\ \text{column two} \end{array} + \left(\begin{array}{r} \text{f-factor} \\ \text{of column} \\ \text{three} \end{array} \times \begin{array}{r} \text{last three} \\ \text{digits of} \\ \text{given S.} \end{array} \right) =$$

$$22.00 \quad .7680 \quad 6.47$$

26.968960 (round to two decimal places) ANSWER 26.97

DENSITY (σ_t)

Salinity 30.00‰ to 39.99‰

T. °C.	σ_t	f	T. °C.	σ_t	f	T. °C.	σ_t	f
25.65	19.40	.7540	27.01	18.98	.7520	28.32	18.56	.7510
.68	.39		.04	.97		.36	.55	
.71	.38		.07	.96		.39	.54	
.75	.37		.11	.95		.42	.53	
.78	.36		.14	.94		.45	.52	
.81	.35		.17	.93		.48	.51	
.85	.34		.20	.92		28.51	18.50	.7510
.88	.33		.23	.91		.54	.49	
.91	.32		.26	.90		.57	.48	
.94	.31		.30	.89		.60	.47	
.98	.30		.33	.88		.63	.46	
			.36	.87		.66	.45	
26.01	19.29	.7530	.39	.86	.69	.44		
.04	.28		.42	.85	.72	.43		
.08	.27		.45	.84	.75	.42		
.11	.26		.48	.83	.78	.41		
.14	.25		27.52	18.82	.81	.40		
.17	.24		.55	.81	.85	.39		
.21	.23		.58	.80	.88	.38		
.24	.22		.61	.79	.91	.37		
.27	.21							

Kalle & Thorade. Tabellen und Tafeln für die Dichte des Seewassers. (Hamburg, 1940)

Sigma-t from temperature and either salinity or chlorinity, with interpolation tables.

About 36 sheets

Dichte = 1 + 0,001 σ_t

t° \ S‰	25.		24.		23.		22.		Cl ‰
	20°	21°	22°	23°	24°	25°	26°	27°	
36,00	54	27 00	71	42 12	81	49 17	84	50	19,928
1	55	28 01	72	43 13	82	50 18	85	51	934
2	56	29 01	72	43 13	82	51 18	85	51	939
3	57	30 02	73	44 14	83	52 19	86	52	945
4	57	30 02	73	44 14	83	52 19	86	52	950
5	58	31 03	74	45 15	84	53 20	87	53	956
6	59	32 04	75	46 16	85	54 21	88	54	961
7	60	33 05	76	47 17	86	55 22	89	55	967
8	61	34 06	77	48 18	87	56 23	90	56	972
9	62	35 07	78	49 19	88	57 24	91	57	978
10	62	35 07	78	49 19	88	57 24	91	57	983
1	63	36 08	79	50 20	89	58 25	92	58	
2	64	37 09	80	51 21	90	59 26	93	59	
3	65	38 10	81	52 22	91	60 27	94	60	
4	66	39 11	82	53 23	92	61 28	95	61	
5	65	38 11	82	53 23	92	60			
6	66	39 12	83	54 23	93				
7	67	40 13	84	55					
8	68	41 14	85						
9	69	42 15							
20	69	42							
1	70								
2									

Einschalttafel

	2	3	4	5	6	7	8	9	10
1	0	0	0	1	1	1	1	1	1
2	0	1	1	1	1	1	2	2	2
3	1	1	1	2	2	2	2	3	3
4	1	1	2	2	2	3	3	4	4
5	1	2	2	3	3	4	4		
6	1	2	2	3	4	4			
7	1	2	3	4	4				
8	2	2	3	4					
9	2	3	4						

Beispiel:

Gegeben S = 36,12‰; t = 18,64°C; gesucht σ_t

Auflösung:

Haupttafel: 36,12‰; 18° 26,15

Diff. f. 1° -25; Einschalttafel { -15

$\sigma_t = 25,99$

Matthews, I.C.E.S. 1932. Sigma-t from sigma-O and temperature. An extended version of Knudsen's tables (see sheet A).

Salinity to sigma-O, 8 sheets
Sigma-t and temperature to sigma-t, 18 sheets.

INSTRUCTIONS FOR USING THE TABLES

These tables are not to be used to calculate *D* for temperatures lower than -2°C or higher than 33°C .

1) If σ_0 is exactly 0.00 or 28.00 the value of *D* can be taken from one of the left hand pages 1, 3, 5 ... opposite a right hand page in which these values of σ_0 are found.

Example: $\sigma_0 = 0.00, t = 11^{\circ}23$. By the tables on pages 11, 13, 17 or 23 *D* is 0.27. This value is accurate to two decimal places for all temperatures from $11^{\circ}23$ to $11^{\circ}32$, but not for $11^{\circ}33$.

Example: $\sigma_0 = 28.00, t = 15^{\circ}46$. By the tables on pages 33, 39, 49, or 53, *D* = 2.23 to two decimal places.

2) If σ_0 is not exactly 0.00 or 28.00, take out the appropriate adjustment from one of the right hand tables, add it to the temperature and then find *D* from the left hand table opposite.

Example: $\sigma_0 = 7.00, t = 12^{\circ}00$. The adjustment is 2.40 by the table on page 20, the adjusted temperature is $14^{\circ}40$ and *D* is 0.66 by the table on page 19 opposite.

Example: $\sigma_0 = 7.08, t = 12^{\circ}63$. Interpolation is necessary for σ_0 and for *t*. Exact interpolation gives 2.38 as the adjustment and *D* is 0.75.

σ_0 : 0.0 to 16.0
t: $1^{\circ}6$ to $2^{\circ}8$

- 7 -

t°	<i>D</i>
-0.98	0.07
-0.86	0.06
-0.74	0.05
-0.64	0.04
-0.48	0.03
-0.35	0.02
-0.21	0.01
-0.07	0.00
0.08	-0.01
0.23	-0.02
0.40	-0.03
0.57	-0.04
0.75	-0.05
0.94	-0.06
1.15	-0.07
1.37	-0.08
1.62	-0.09
1.89	-0.10
2.20	-0.11
2.60	-0.12
3.16	-0.13

	$1^{\circ}6$	$1^{\circ}7$	$1^{\circ}8$	$1^{\circ}9$	$2^{\circ}0$	$2^{\circ}1$	$2^{\circ}2$	$2^{\circ}3$	$2^{\circ}4$	$2^{\circ}5$	$2^{\circ}6$	$2^{\circ}7$	$2^{\circ}8$
0.0	0.0	0.0	0.0	0.0	0.0	0.0	0.0	0.0	0.0	0.0	0.0	0.0	0.0
1.0	-0.2	-0.2	-0.2	-0.2	-0.3	-0.3	-0.3	-0.4	-0.4	-0.4	-0.5	-0.5	-0.5
1.5	.2	.3	.3	.3	.4	.4	.5	.5	.5	.6	.6	.7	.7
2.0	.3	.4	.4	.4	.5	.5	.6	.6	.7	.7	.8	.9	.9
2.5	.4	.5	.5	.5	.6	.6	.7	.8	-0.8	-0.9	-0.9	-1.0	-1.0
3.0	.6	.6	.6	.6	.7	.8	.8	-0.9	-1.0	-1.0	-1.1	-1.1	-1.2
3.5	.6	.6	.7	.7	.8	-0.9	-0.9	-1.0	-1.1	-1.1	-1.2	-1.3	-1.3
4.0	.7	.7	.8	.8	-0.9	-1.0	-1.0	-1.1	-1.2	-1.2	-1.3	-1.4	-1.4
4.5	.8	.8	.8	-0.9	-1.0	-1.1	-1.1	-1.2	-1.3	-1.4	-1.5	-1.6	-1.6
5.0	-0.8	-0.9	-0.9	-1.0	-1.1	-1.2	-1.2	-1.3	-1.4	-1.5	-1.6	-1.7	-1.8
5.5	-0.9	-0.9	-1.0	1	2	3	3	4	5	6	7	8	-1.9
6.0	-1.0	-1.0	1	2	3	3	4	5	6	7	8	-1.9	-2.1
6.5	.1	.0	.2	.2	.3	.4	.5	.6	.7	.8	-1.9	-2.1	.3
7.0	.1	.1	.2	.3	.4	.4	.6	.7	.8	-1.9	-2.0	.2	.3
7.5	.2	.2	.3	.4	.5	.5	.7	.8	-1.9	-2.0	.1	.3	.4
8.0	.2	.3	.4	.5	.6	.6	.8	-1.9	-2.0	.1	.2	.4	.5
8.5	.2	.3	.4	.5	.6	.7	.9	-2.0	.1	.2	.3	.5	.6
9.0	.3	.4	.5	.6	.7	.8	-1.9	.1	.2	.3	.4	.5	.7
9.5	.3	.4	.5	.7	.8	.9	-2.0	.1	.2	.4	.5	.6	.8
10.0	-1.4	-1.5	-1.6	-1.7	-1.8	-1.9	-2.0	-2.1	-2.2	-2.3	-2.4	-2.5	-2.6
10.5	.4	.5	.7	.7	-1.9	-2.0	.15	.25	.40	.50	.65	.80	-2.90
11.0	.5	.6	.7	.8	-2.0	.10	.20	.35	.45	.60	.75	.85	-3.00
11.5	.6	.7	.8	-1.9	.0	.15	.30	.40	.55	.70	.80	-2.95	.10
12.0	.6	.7	.8	-2.0	.1	.20	.35	.50	.60	.75	.90	-3.00	.15
12.5	.7	.8	-1.9	.0	.2	.25	.40	.55	.70	.80	-2.95	.10	.25
13.0	.7	.8	-2.0	.1	.2	.30	.50	.60	.75	.90	-3.05	.20	.30
13.5	.8	.9	.0	.1	.3	.40	.55	.70	.80	-2.95	.10	.25	.40
14.0	.8	-1.9	.1	.2	.3	.45	.60	.75	.90	-3.05	.15	.30	.45
14.5	.8	-2.0	.2	.2	.4	.50	.65	.80	-2.95	.10	.25	.40	.55
15.0	-1.9	-2.0	-2.2	-2.3	-2.4	-2.00	-2.70	-2.85	-3.00	-3.15	-3.30	-3.45	-3.60
15.5	-1.9	.0	.2	.3	.5	.65	.75	.90	.05	.20	.35	.50	.65
16.0	-2.0	.1	.2	.4	.5	.70	.80	.95	.10	.30	.45	.60	.75

Example: $\sigma_0 = 13.62$
observed temperature = $2^{\circ}13$
adjustment = $-2^{\circ}45$
adjusted temperature = $-0^{\circ}32$

United States Hydrographic Office publication 615. Sigma-t from temperature and salinity. The most detailed tables available, but very bulky. About 60 sheets.

S‰		11	12	13	14	15	16	17	18	19	20
T°C											
16	50	340	103	865	628	390	151	913	675	436	198
16	51	339	101	864	626	388	149	911	673	434	196
16	52	337	099	862	624	386	147	909	671	432	194
16	53	335	097	860	622	384	145	907	669	430	192
16	54	333	095	858	620	382	143	905	667	428	190
16	55	331	093	856	618	380	141	903	665	426	188
16	56	329	092	854	616	378	139	901	663	424	186
16	57	327	090	852	614	376	137	899	661	422	184
16	58	325	088	850	612	374	135	897	659	420	182
16	59	323	086	848	610	372	133	895	657	418	180
16	60	321	084	846	608	370	131	893	655	416	177
16	61	320	082	844	606	368	129	891	652	414	175
16	62	318	080	842	604	366	127	889	650	412	173
16	63	316	078	840	602	364	125	887	648	410	171
16	64	314	076	838	600	362	123	885	646	408	169
16	65	312	074	836	598	360	121	883	644	406	167
16	66	310	072	834	596	358	119	881	642	404	165
16	67	308	070	832	594	356	117	879	640	402	163
16	68	306	068	830	592	354	115	877	638	400	161
16	69	304	067	829	590	352	113	875	636	397	159
16	70	302	065	827	588	350	111	873	634	395	157
16	71	300	063	825	586	348	109	871	632	393	155
16	72	298	061	823	584	346	107	869	630	391	152
16	73	297	059	821	582	344	105	867	628	389	150
16	74	295	057	819	580	342	103	865	626	387	148
16	75	293	055	817	578	340	101	863	624	385	146
16	76	291	053	815	576	338	099	861	622	383	144
16	77	289	051	813	575	336	097	859	620	381	142
16	78	287	049	811	573	334	095	857	618	379	140
16	79	285	047	809	571	332	093	854	616	377	138
16	80	283	045	807	569	330	091	852	614	375	136
16	81	281	043	805	567	328	089	850	612	373	134
16	82	279	041	803	565	326	087	848	609	371	132
16	83	277	039	801	563	324	085	846	607	368	129
16	84	275	037	799	561	322	083	844	605	366	127
16	85	273	035	797	559	320	081	842	603	364	125
16	86	272	033	795	557	318	079	840	601	362	123
16	87	270	032	793	555	316	077	838	599	360	121
16	88	268	030	791	553	314	075	836	597	358	119
16	89	266	028	789	551	312	073	834	595	356	117
16	90	264	026	787	549	310	071	832	593	354	115
16	91	262	024	785	547	308	069	830	591	352	113
16	92	260	022	783	545	306	067	828	589	350	111
16	93	258	020	781	543	304	065	826	587	348	108
16	94	256	018	779	541	302	063	824	585	346	106
16	95	254	016	777	539	300	061	822	583	343	104
16	96	252	014	775	537	298	059	820	581	341	102
16	97	250	012	773	535	296	057	818	578	339	100
16	98	248	010	771	533	294	055	816	576	337	098
16	99	246	008	769	531	292	053	814	574	335	096
ΔS		762	762	762	762	761	762	761	761	761	761

United States Hydrographic Office publication 614.

Similar to previous sheet, but given to one less decimal of temperature, so that interpolation is needed in both variables.

7 sheets.

OCEANOGRAPHIC TABLES

93

TABLE X.—SIGMA-T FOR VALUES OF TEMPERATURE AND SALINITY—Continued

Temperature, ° C.	Salinity, ‰								
	30	31	32	33	34	35	36	37	38
7.0.....	23.512	24.297	25.082	25.867	26.653	27.439	28.226	29.014	29.802
7.1.....	23.499	24.284	25.068	25.853	26.639	27.425	28.212	28.999	29.788
7.2.....	23.486	24.270	25.055	25.840	26.625	27.411	28.198	28.985	29.773
7.3.....	23.473	24.257	25.041	25.826	26.611	27.397	28.183	28.970	29.758
7.4.....	23.460	24.244	25.028	25.812	26.597	27.383	28.169	28.955	29.743
7.5.....	23.447	24.230	25.014	25.798	26.583	27.368	28.154	28.940	29.727
7.6.....	23.434	24.217	25.000	25.784	26.569	27.353	28.139	28.925	29.712
7.7.....	23.420	24.203	24.986	25.770	26.554	27.339	28.124	28.910	29.697
7.8.....	23.406	24.189	24.972	25.756	26.539	27.324	28.109	28.895	29.681
7.9.....	23.393	24.175	24.958	25.741	26.525	27.309	28.094	28.879	29.665
8.0.....	23.379	24.161	24.944	25.727	26.510	27.294	28.079	28.864	29.650
8.1.....	23.365	24.147	24.929	25.712	26.495	27.279	28.063	28.848	29.634
8.2.....	23.351	24.133	24.915	25.697	26.480	27.264	28.048	28.832	29.618
8.3.....	23.337	24.118	24.900	25.682	26.465	27.248	28.032	28.817	29.602
8.4.....	23.323	24.104	24.885	25.667	26.450	27.233	28.016	28.801	29.586
8.5.....	23.308	24.089	24.870	25.652	26.434	27.217	28.001	28.785	29.569
8.6.....	23.294	24.074	24.855	25.637	26.419	27.202	27.985	28.769	29.553
8.7.....	23.279	24.060	24.840	25.622	26.403	27.186	27.969	28.752	29.537
8.8.....	23.264	24.045	24.825	25.606	26.388	27.170	27.953	28.736	29.520
8.9.....	23.250	24.030	24.810	25.591	26.372	27.154	27.936	28.720	29.503
9.0.....	23.235	24.014	24.795	25.575	26.356	27.138	27.920	28.703	29.487
9.1.....	23.220	23.999	24.779	25.559	26.340	27.122	27.904	28.686	29.470
9.2.....	23.204	23.984	24.763	25.544	26.324	27.105	27.887	28.670	29.453
9.3.....	23.189	23.968	24.748	25.528	26.308	27.089	27.871	28.653	29.436
9.4.....	23.174	23.953	24.732	25.512	26.292	27.072	27.854	28.636	29.418
9.5.....	23.158	23.937	24.716	25.495	26.275	27.056	27.837	28.619	29.401
9.6.....	23.143	23.921	24.700	25.479	26.259	27.039	27.820	28.602	29.384
9.7.....	23.127	23.905	24.684	25.463	26.242	27.022	27.803	28.584	29.366
9.8.....	23.111	23.889	24.668	25.446	26.226	27.005	27.786	28.567	29.349
9.9.....	23.096	23.873	24.651	25.430	26.209	26.988	27.769	28.549	29.331

Fleming, in J. Marine Res. (1939) 2 9-11.

Reverse table of salinity from sigma-t. Useful for entering sigma-t curves on S-T diagrams.

2 sheets.

TABLE I

TABLES FOR σ_t Values of the salinity (‰) corresponding to unit values of σ_t and temperature

Temp. σ_t	18.00	19.00	20.00	21.00	22.00	23.00	24.00	25.00	26.00	27.00	28.00	29.00	30.00
-2° C.	22.40	23.66	24.88	26.11	27.35	28.59	29.82	31.06	32.29	33.52	34.75	35.98	37.21
-1	22.40	23.64	24.88	26.12	27.36	28.60	29.84	31.08	32.31	33.55	34.78	36.02	37.26
0	22.41	23.66	24.90	26.14	27.39	28.63	29.87	31.11	32.36	33.60	34.85	36.09	37.33
1	22.43	23.69	24.94	26.18	27.43	28.68	29.93	31.18	32.43	33.68	34.92	36.16	37.41
2	22.48	23.73	24.99	26.24	27.50	28.76	30.01	31.26	32.51	33.76	35.01	36.26	37.51
3	22.55	23.80	25.06	26.31	27.57	28.83	30.09	31.35	32.61	33.87	35.12	36.37	37.62
4	22.62	23.88	25.15	26.41	27.67	28.93	30.19	31.46	32.72	33.99	35.25	36.50	37.75
5	22.72	23.98	25.25	26.52	27.78	29.05	30.32	31.59	32.86	34.13	35.39	36.65	37.91
6	22.83	24.10	25.38	26.65	27.92	29.19	30.47	31.74	33.01	34.27	35.53	36.80	38.06
7	22.97	24.24	25.52	26.79	28.07	29.35	30.62	31.90	33.17	34.44	35.71	36.98	38.25
8	23.12	24.40	25.67	26.95	28.23	29.52	30.79	32.07	33.35	34.63	35.90	37.18	38.45
9	23.28	24.57	25.86	27.14	28.42	29.70	30.98	32.26	33.54	34.82	36.10	37.38	38.66
10	23.46	24.75	26.04	27.32	28.61	29.90	31.18	32.47	33.75	35.04	36.32	37.60	38.88
11	23.66	24.95	26.24	27.53	28.82	30.11	31.40	32.69	33.97	35.26	36.55	37.83	39.11
12	23.86	25.16	26.46	27.75	29.04	30.34	31.63	32.92	34.22	35.50	36.79	38.08	39.36
13	24.09	25.39	26.69	27.99	29.29	30.59	31.88	33.18	34.47	35.76	37.05	38.34	39.62
14	24.33	25.63	26.94	28.24	29.54	30.84	32.14	33.44	34.74	36.04	37.33	38.62	39.91
15	24.59	25.89	27.20	28.50	29.80	31.10	32.41	33.71	35.01	36.31	37.61	38.90	40.19
16	24.85	26.16	27.47	28.78	30.08	31.39	32.70	34.00	35.30	36.60	37.91	39.21	40.50
17	25.14	26.45	27.75	29.06	30.38	31.69	32.99	34.30	35.61	36.92	38.22	39.52	40.81
18	25.43	26.75	28.06	29.38	30.69	32.00	33.31	34.62	35.93	37.23	38.54	39.85	41.15
19	25.75	27.07	28.38	29.69	31.01	32.32	33.64	34.95	36.26	37.57	38.87	40.18	41.48
20	26.07	27.39	28.71	30.03	31.35	32.66	33.97	35.29	36.60	37.91	39.22	40.53	
21	26.40	27.72	29.04	30.37	31.69	33.01	34.33	35.64	36.95	38.26	39.58	40.89	
22	26.75	28.07	29.40	30.72	32.05	33.37	34.69	36.00	37.32	38.64	39.95	41.26	

TABLE II

INTERPOLATION TABLE FOR FRACTIONAL VALUES OF σ_t

Salinity difference	0.1	0.2	0.3	0.4	0.5	0.6	0.7	0.8	0.9
1.22 ‰	0.12 ‰	0.24 ‰	0.37 ‰	0.49 ‰	0.61 ‰	0.73 ‰	0.85 ‰	0.98 ‰	1.10 ‰
1.23	.12	.25	.37	.49	.62	.74	.86	.98	1.11
1.24	.12	.25	.37	.50	.62	.74	.87	.99	1.12
1.25	.12	.25	.38	.50	.62	.75	.88	1.00	1.12
1.26	.13	.25	.38	.50	.63	.76	.88	1.01	1.13
1.27	.13	.25	.38	.51	.64	.76	.89	1.02	1.14
1.28	.13	.26	.38	.51	.64	.77	.90	1.02	1.15
1.29	.13	.26	.39	.52	.64	.77	.90	1.03	1.16
1.30	.13	.26	.39	.52	.65	.78	.91	1.04	1.17
1.31	.13	.26	.39	.52	.66	.79	.92	1.05	1.18
1.32	.13	.26	.40	.53	.66	.79	.92	1.06	1.19
1.33	.13	.27	.40	.53	.66	.80	.93	1.06	1.20
1.34	.13	.27	.40	.54	.67	.80	.94	1.07	1.21
1.35	.14	.27	.40	.54	.68	.81	.94	1.08	1.22

Bjerknes, Hydrographic tables. Specific volume from Salinity, Pressure and Temperature.

Basic table of specific volume - pressure, plus six correction tables for salinity, temperature and pressure combinations. About 12 large sheets. On our page size, perhaps 20 sheets.

Table 8 H (continued from p. 7A).— $10^6 a_{35,0,p}$ ($a_{35,0,p}$ = specific volume of sea-water of 35 ‰ salinity and 0° C. at standard pressure, expressed in m³/tons).

Sea-pressure (decibars)	0	10	20	30	40	50	60	70	80	90
5000	95173	95169	95165	95161	95157	95154	95150	95146	95142	95138
5100	95134	95130	95127	95123	95119	95115	95111	95107	95103	95100
5200	95096	95092	95088	95084	95080	95077	95073	95069	95065	95061
5300	95057	95054	95050	95046	95042	95038	95034	95031	95027	95023
5400	95019	95015	95011	95008	95004	95000	94996	94992	94988	94985
5500	94981	94977	94973	94969	94966	94962	94958	94954	94950	94947
5600	94943	94939	94935	94931	94928	94924	94920	94916	94912	94909
5700	94905	94901	94897	94893	94890	94886	94882	94878	94874	94871
5800	94867	94863	94859	94856	94852	94848	94844	94840	94837	94833
5900	94829	94825	94822	94818	94814	94810	94807	94803	94799	94795
6000	94791	94788	94784	94780	94776	94773	94769	94765	94761	94758
6100	94754	94750	94746	94743	94739	94735	94731	94728	94724	94720

Basic table

Table 13 H.— $10^5 \cdot \delta_{tp}$ (δ_{tp} = combined temperature-pressure correction in m³/ton to the specific volume of sea-water).

Sea-pressure (decibars)	Temperature (° C.)																																	
	-2	-1	0	1	2	3	4	5	6	7	8	9	10	11	12	13	14	15	16	17	18	19	20	21	22	23	24	25	26	27	28	29	30	
0	0	0	0	0	0	0	0	0	0	0	0	0	0	0	0	0	0	0	0	0	0	0	0	0	0	0	0	0	0	0	0	0	0	
100	1	0	0	0	1	1	1	1	1	2	2	2	2	3	3	3	3	3	3	3	3	3	3	3	3	3	3	3	3	3	3	3	3	3
200	1	1	0	1	1	1	2	2	3	3	4	4	4	5	5	5	5	5	5	5	5	5	5	5	5	5	5	5	5	5	5	5	5	5
300	2	1	0	1	2	2	3	4	4	5	5	6	7	7	8	8	8	9	9	9	10	10	10	11	11	11	11	11	11	11	11	11	11	11
400	2	1	0	1	2	3	4	5	6	6	7	8	9	9	10	11	11	12	12	13	13	14	14	14	15	15	15	15	16	16	16	16	17	17
500	3	1	0	1	3	4	5	6	7	8	9	10	11	12	12	13	14	15	15	16	16	17	17	18	18	19	19	19	20	20	21	21	21	21
600	3	2	0	2	3	5	6	7	8	10	11	12	13	14	15	16	17	17	18	19	20	21	21	22	22	23	23	24	24	24	25	25	25	25
700	4	2	0	2	4	5	7	8	10	11	13	14	15	16	17	18	19	20	21	22	23	23	24	25	25	26	26	27	27	28	28	29	29	29
800	4	2	0	2	4	6	8	10	11	13	14	16	17	18	20	21	22	23	24	25	26	27	27	28	29	30	30	31	31	32	32	33	33	33
900	5	2	0	2	5	7	9	11	13	14	16	18	19	21	22	23	25	26	27	28	29	30	31	32	32	33	34	35	35	36	36	37	37	

One of the correction tables

Zubov & Gzihirin. Oceanological Tables, Moscow 1940

Specific volume from temperature, salinity and pressure. Basic table from salinity and temperature, with four correction tables. Precision similar to Bjerknes' table, but needs more interpolation in the pressure corrections. Probably easier to read.

Basic table 8 sheets. Given at closer spacing in the deep water range, but do not cover Mediterranean or Red Sea. Correction tables 6 sheets. Would fit onto our format with only slight reduction.

T. 14. Conditional specific volume of ocean waters

35.0	35.1	35.2	35.3	35.4	35.5	35.6	35.7	35.8	35.9	36.0	$\frac{S}{\rho}$
72.57	72.49	72.41	72.33	72.26	72.19	72.11	72.03	71.95	71.87	71.80	-2.0
.57	.50	.42	.33	.26	.19	.11	.03	.95	.88	.81	-1.9
.57	.50	.42	.34	.27	.20	.11	.03	.95	.88	.81	.8
.57	.50	.42	.34	.27	.20	.12	.04	.95	.88	.81	.7
.58	.51	.42	.34	.27	.20	.12	.04	.96	.89	.82	.6
.58	.51	.43	.35	.28	.20	.12	.04	.96	.89	.82	.5
.58	.51	.43	.35	.28	.21	.13	.05	.96	.89	.82	.4
.59	.52	.43	.35	.28	.21	.13	.05	.97	.90	.83	.3
.59	.52	.44	.36	.29	.21	.13	.05	.97	.90	.83	.2
.59	.52	.44	.36	.29	.22	.14	.06	.98	.90	.83	.1
72.60	72.52	72.45	72.36	72.29	72.22	72.14	72.06	71.98	71.91	71.84	-1.0
.60	.52	.45	.37	.30	.23	.15	.06	.98	.91	.84	-0.9

Basic Table

T. 18. Correction (δv) to specific volume for temperature and pressure

$$v_{pts} = v_t + \delta_p + \delta_{tp} + \delta_{sp} + \delta_{isp}$$

10	12	14	16	18	20	22	24	26	28	30	$\frac{P}{\rho}$
0	0	0	0	0	0	0	0	0	0	0	0
0.02	0.03	0.03	0.03	0.03	0.03	0.04	0.04	0.04	0.04	0.04	100
.04	.05	.05	.06	.06	.07	.07	.08	.08	.08	.08	200
.07	.08	.08	.09	.10	.10	.11	.11	.12	.12	.13	300
.09	.10	.11	.12	.13	.14	.15	.15	.16	.16	.17	400
0.11	0.12	0.14	0.15	0.16	0.17	0.18	0.19	0.20	0.20	0.21	500
.13	.15	.17	.18	.20	.21	.22	.23	.24	.24	.25	600
.15	.17	.19	.21	.23	.24	.25	.26	.27	.28	.29	700
.17	.20	.22	.24	.26	.27	.29	.30	.31	.32	.33	800
.19	.22	.25	.27	.29	.31	.32	.34	.35	.36	.37	900

Sample of correction table

Fofonoff & Froese, Tables of Physical Properties of Sea Water.
(Fisheries Res. Bd. of Canada Manuscript report No. 24, 1958)

Specific volume at fairly wide intervals of temperature, salinity and pressure, with derivatives for interpolation. Designed for use with electronic computer, rather than for the occasional individual observation. 25 large sheets, probably 40 on our format.

units in every case are:

temperature	t° C or T° Absolute
Salinity	S ‰
pressure	p decibars.

In Table 1, the specific volume α is tabulated as well as the derivatives $\alpha_t = \frac{\partial \alpha}{\partial t}$, $\alpha_s = \frac{\partial \alpha}{\partial S}$, $\alpha_{tt} = \frac{\partial^2 \alpha}{\partial t^2}$, $\alpha_{ss} = \frac{\partial^2 \alpha}{\partial S^2}$, and $\alpha_{st} = \frac{\partial^2 \alpha}{\partial S \partial t}$. The temperatures t and salinities S have been scaled by 10^2 , the α 's by 10^9 , and all derivatives by 10^{10} . The truncation errors in α_t are ~ 2 in the fifth figure; in α_s , ~ 2 in the sixth figure; the last two figures in the second derivatives are not significant.

Table 1 (cont'd). Specific volume, α , and derivatives of α .

S = 3400		P = 03000				
t	α	α_t	α_s	α_{tt}	α_{ss}	α_{st}
-0200	0960200547	1006023	-7250746	111497	006780	023241
0000	0960423455	1219604	-7205940	102333	006072	021574
0200	0960687331	1416252	-7164403	094585	005513	019981
0400	0960989068	1598661	-7126005	088065	004954	018440
0600	0961326053	1769131	-7090643	082552	004433	016940
0800	0961696105	1929681	-7058205	078082	004023	015506
1000	0962097414	2082050	-7028584	074375	003706	014114

S = 3500		P = 03000				
t	α	α_t	α_s	α_{tt}	α_{ss}	α_{st}
-0200	0959475808	1029074	-7244148	110678	006388	022868
0000	0959703160	1241019	-7200045	101495	005699	021252
0200	0959971160	1426025	-7150102	092781	005102	019682

Unesco technical papers
in marine science
no. 4

I.O.C. Tech. Ref.

Second report of the joint panel
on oceanographic tables and standards

held in Rome

8-9 October 1965

sponsored by

UNESCO, ICES, SCOR, IAPO

Unesco

SECOND REPORT OF THE JOINT PANEL ON
OCEANOGRAPHIC TABLES AND STANDARDS

held in

Rome, 8-9 October 1965

Jointly sponsored by the

United Nations Educational, Scientific and Cultural Organization

International Council for the Exploration of the Sea

Scientific Committee on Oceanic Research

International Association of Physical Oceanography

The scientific views expressed here
are those of experts participating
in the work of the Panel and not
necessarily those of Unesco or other
sponsoring organizations.

INTRODUCTION

1. This report follows a meeting of the panel in Rome on 8-9 October 1965. A panel meeting on 8 October was attended by:

Dr. R.A. Cox (Great Britain) in the chair
Professor G. Dietrich (Germany)
Dr. K.N. Fedorov (Unesco)
Dr. N.P. Fofonoff (U.S.A.)
Mr. F. Hermann (Denmark)
Dr. G.N. Ivanoff-Frantzkevich (USSR)
Professor Y. Miyake (Japan)
Professor O. Saalen (Norway)

Guests at the meeting included Dr. Grasshoff (Germany), Mr. Menaché (France) and Dr. Morcos (Egypt). An apology for his unavoidable absence was received from Professor Carritt (U.S.A.).

On 9 October an open meeting was held, attended by a number of delegates to the annual meeting of ICES, which was in progress in Rome. In addition to the members of the panel, about 25 scientists were present. The chairman gave an account of the recent work, and of the decisions of the panel, which will be discussed later in this report. Mr. Maurice Menaché (France) read a paper entitled "Variation de la Masse Volumique de l'eau en fonction de sa Composition Isotopique." As this paper will shortly be published in "Cahiers Oceanographiques" it is not included with this report, but will be referred to in section 2c.

The chairman introduced two papers by Messrs. H. Charnock and J. Crease (Great Britain) entitled "The specification of salinity estimators" and "A salinity estimator based on conductivity ratio", (these papers are appended to this report as appendices A and B) and a short paper by Dr. J.S.M. Rusby (Great Britain) on "Measurement of refractive index of sea-water samples". (Appendix C).

The open meeting was followed on the afternoon of 9 October by a further committee meeting. It was resolved that this report should be prepared, to make known and explain the decisions of the committee. The chairman agreed to prepare a provisional draft, and Dr. Fofonoff and Professor Miyake undertook to draft certain sections. Dr. Fedorov promised that the report would be published in the series of "Unesco technical papers in Marine Science".

This introduction is followed by an account by the chairman of the work done since the last report (October 1964).

2. WORK COMPLETED SINCE THE LAST REPORT OF THE PANEL

(a) Chlorinity determinations

At the last meeting of the panel (Charlottenlund, October 1964) it was resolved that in view of the importance to future work, and of the doubts which had been raised regarding the reliability of the determinations of chlorinity by Riley and his co-workers, it was necessary to repeat at least a considerable proportion of these chlorinity determinations. This has been done. In the original

measurements (see Cox, Culkin, Greenhalgh and Riley, 1962) about 450 samples were analysed. It was arranged that about 350 of these should be analysed again; the samples were divided between Dr. Riley at Liverpool University and Dr. Culkin at the National Institute of Oceanography. From this total about 100 samples were selected where a good supply of water was still available, and these were re-measured by both analysts. In addition to redetermining the chlorinity, Dr. Culkin also rechecked the conductivity ratio, in most cases using only one tube of water for both measurements.

The results are discussed in detail in the report by Charnock and Crease (Appendix B) but will be summarized here. Statistical treatment shows quite clearly that Dr. Culkin's results are very decidedly more consistent than Dr. Riley's, while there is no significant improvement in Dr. Riley's second set of determinations compared with his earlier set. Using each set of determinations on its own, a fourth order curve was fitted by least squares, expressing chlorinity as a function of conductivity ratio. The standard deviation of Dr. Culkin's chlorinities from the curve was about 0.002‰, while Dr. Riley's was over 0.006‰. The mean square difference between Dr. Riley's first and second determination on the same sample was also over 0.006‰.

The reasons for the inaccuracies in Riley's measurements are not at present clear. They are not shown in replicate determinations at one time on one sample; for such replicates the standard deviation is much less, about 0.001‰. The basic differences in the methods used are two; firstly, Culkin weighs both the sea water and the strong silver nitrate used in the titration, while Riley weighs only the water and uses a burette to measure the silver; secondly, although both workers use an electrometric end-point, the electrode systems are different. Riley's technique is described in Bather and Riley (1953), while Culkin's are based on those of Hermann (1951).

The samples determined by Dr. Culkin cover the whole range of salinity from Baltic water to Red Sea. They have not, however, been selected specifically to cover the whole range at close intervals. If these results were to be used alone to compute conductivity/chlorinity relationships, it might be necessary to undertake a few extra measurements to fill in gaps in the series, especially at low salinities.

(b) Conductivity/salinity tables

Based on Dr. Riley's chlorinity values, tables have been computed connecting conductivity ratio at 15° with salinity. The salinity range is 30-42‰ and the interval 0.00001 in conductivity ratio. In addition, a second table gives corrections to conductivity ratio when measured at temperatures other than 15°. These two tables had been printed in the format agreed at the previous meeting, and copies were distributed for inspection.

The chairman also distributed a copy of the computer print-out for a table covering the range 3-42‰ in salinity, at intervals of 0.0001 in ratio. He also showed a temperature correction table for this wider range, but explained he was not yet satisfied with the results from which these corrections were computed. A more extensive series of measurements was under way. (These are now finished. See section 3. Editor).

(c) Density determinations

No actual determinations had been made in the last year. The apparatus for specific gravity measurements was under reconstruction. It should be working in its improved form early in 1966.

However some work had been done on the preparation of water suitable for use as reference in specific gravity work.

Mr. Menaché's report (see section 1) shows that substantial variations exist in the isotopic ratios of natural waters, and these have a significant effect on the specific gravity. Variations in the isotopic ratios of sea water, however, are very much smaller than between, for example, sea water and polar snowfall. It would seem that water distilled from sea water should offer a suitable standard for specific gravity measurement.

The chairman circulated copies of a report (N.I.O. internal report C5. "Distilled water for relative density standard" by R.A. Cox and M.J. McCartney, March 1965) which would shortly be published in the literature. (In Deep-Sea Research - Editor.) It had been found possible to distil pure water from sea water in such a way that the isotope ratios were not significantly changed. This was confirmed by isotopic analysis of the distillate and of water similar to the original sea water.

The isotopic analyses (kindly undertaken by Professor Dansgaard in Copenhagen show that our distilled water is fractionally higher in heavy isotopes of hydrogen and oxygen than is Standard Mean Ocean Water (Craig, 1961). The results of Menaché, however, indicate that this small difference will not introduce a significant difference in density. Such distilled water seemed very suitable as a standard for specific gravity determinations.

(d) Refractive index determinations

The chairman presented a short report by Dr. Rusby (see Appendix C). The measurements at 20° were very encouraging, and could form the basis for tables connecting refractive index anomaly (Δn , the difference between the refractive index of the sample and that of water of salinity 35‰) and salinity or chlorinity. However there was some evidence that Δn depended somewhat on temperature, so that as with conductivity/salinity tables a temperature correction might be needed. Measurements were in progress at various temperatures, from which this correction could be computed.

(e) Absolute conductivity apparatus

This apparatus was complete, and working. The final trials had to await the calibration of the thermometer, precision resistors and length standards by the N.P.L. However a preliminary trial run had given a value for the conductivity of sea water of salinity 35‰ at 15° of 0.04286 ohms⁻¹ cm⁻¹, compared with the figure of 0.04288 interpolated from the results of Thomas et al (1934).

If all went well with the calibrations, the apparatus should be tested and operational early in 1966. It would then be taken over by the Standard Sea Water Service, and used to standardize the conductivity of the standard water. The label on the standard water would then show the conductivity (and salinity computed from it) as well as the chlorinity.

3. THE NEW CONDUCTIVITY-CHLORINITY TABLES

The new tables for converting conductivity measurements to salinity will be distributed early in 1966, and the panel feels it appropriate to restate the reasons leading to the preparation of the tables, and the principles which have directed the work.

Because there is no general agreement, even among English-speaking scientists, on the exact meaning of some terms which will be used in this section, definitions are given below, and where these terms are used hereafter in this section it will be in accord with these definitions.

Determine, determination. A determination is an actual measurement of the variable concerned, the accuracy being limited only by the experimental limitations of the method.

Estimate, estimation. An estimation is a value for one variable derived from a determination of another; for example, we may determine chlorinity, and from the chlorinity estimate specific gravity. The accuracy of the result depends not only on the precision of the chlorinity determination, but also on our knowledge of the conversion factor, and on any natural scatter in this factor due, for example, to variations in sea water composition.

Accuracy. The difference between the result obtained and the true result, a high accuracy implying a small difference and a low accuracy a larger difference.

Precision. The difference (usually expressed as the root mean square difference, or standard deviation) between a single result and the mean of a large number of results by the same method. The precision represents the reproducibility of a method; it is not the same as the accuracy, because the method may be a bad one, and give a wrong answer. Thus a method may be precise, because it gives a consistent answer, but still be inaccurate, because the answer is wrong.

We all know the general concept of salinity. It expresses the concentration of dissolved solids in sea water, measured in parts per thousand of sea water by weight. Unfortunately, salinity is a very difficult quantity to determine directly, and it has been necessary in practice to estimate salinity from measurements of some other parameter. The problem facing the panel is to ensure that whatever method is used for salinity estimation, the final figure which we obtain will be as nearly as is possible the same.

During the discussion in Rome, Dr. Fedorov put forward a very helpful analogy between salinity and temperature. Like salinity, temperature is a concept rather than a clearly defined property. It expresses the heat-content of matter, just as salinity expresses salt content of water. We cannot measure temperature directly; what we measure is some property dependent on it, such as the expansion of mercury

or the resistance of a platinum wire. Both concepts have their absolute zero-with temperature, when all thermal energy is absent; with salinity, when the water is pure and free of salt. Unfortunately with salinity we do not have any other fixed points, like the freezing and boiling points of water which assist in fixing temperature scales.

The traditional parameter used for estimating salinity is the chlorinity determination, which measures chloride and bromide in the sea water by weight, usually by a volumetric procedure using a standard sea water as reference. The chlorinity scale was defined by Jacobsen and Knudsen (1940) with pure silver as the standard. The only assumption in this definition is that the ratio of chloride to bromide in sea water is constant; the available evidence, including that from the recent work, shows that this assumption is justified as nearly as we can tell.

Salinity has usually been estimated from chlorinity by the equation proposed by Forch, Knudsen and Sørensen (1902), which is based on determinations of chlorinity and salinity on a number of natural sea waters, including several from the Baltic Sea. From these analyses the well known relationship

$$S \text{ ‰} = 1.805 \text{ Cl ‰} + 0.03$$

was deduced. To obtain this equation, Sørensen defined "salinity" in an arbitrary way, which is certainly related to the dissolved salts, but disregards the bicarbonate and some other volatile ions. The constant 0.03 represents approximately the solid content of river water flowing into the Baltic, disregarding the bicarbonate ion. This solid content is partly calcium sulphate, but mostly calcium bicarbonate which in the Sørensen salinity determination is converted to oxide, and weighed as such. Conductivity measurements, however, estimate also the bicarbonate ions, as well as traces of other volatile components such as organic acids which are not measured in the Sørensen methods. Thus if we prepare an equation between salinity and conductivity ratio, (R), defining salinity as chlorinity multiplied by a constant, we get

$$S \text{ ‰} = x \text{ Cl ‰} = aR + bR^2 + cR^3 + \text{----} -0.09$$

The intercept, 0.09 ‰, is the apparent salinity at zero chlorinity, and represents dissolved ionic material in river water, whereas the Sørensen 0.03 ‰ represents (mainly) calcium oxide. Thus if we wish to prepare an expression relating conductivity and salinity, to include Baltic Sea samples, and to make our "salinity" the best possible measure of ionic content, then we should start by estimating salinity from our chlorinities using

$$S \text{ ‰} = 1.802 \text{ Cl ‰} + 0.09$$

rather than the Sørensen formula.

The real point is this; even when dealing with samples from the Baltic Sea, the Sørensen 0.03 has a real significance only when referred to an arbitrary method of determination, and has little meaning when considering conductivity measurements. This is even more true when considering other low salinity waters, as there is no evidence that the conductivity at zero chlorinity would correspond with that found in the Baltic area.

A further problem arises when considering dilution of sea water by pure water. When sea water is diluted by rain, or by melting polar ice, it is convenient to calculate the salinity of the diluted water from the weights of salt water and fresh water in the mixture. If we define salinity as a $Cl\ \% + b$, then the salinity of the mixture is not in direct proportion to that of the constituents; for example, if a given weight of salt water is diluted with an equal weight of fresh, the chlorinity in the mixture will be half the original value, but the salinity will not. This is confusing, and in a relationship claiming to be a weight ratio, grammes per kilogramme of water, it is quite illogical.

The simple solution to all these problems would seem to be to abandon the term salinity, and report our observations as conductivity ratio or chlorinity. The second alternative, to report as chlorinity, has the objection that conductivity and chlorinity are not exactly related, due to variations in composition of sea water. Some means must be used to distinguish actual chemical chlorinity determinations, (which are often valuable data) from conductivity measurements. Conductivity, however, has at present little significance to most oceanographers, and none at all to many, particularly those such as biologists and geologists not directly concerned with salinity measurements. To most people reading this report a salinity of 33.04 ‰ will mean something; a conductivity ratio of 0.950 will not. Also the various data centres are equipped to record salinity, not conductivity; millions of such records exist, and it would be prohibitively expensive to change them.

There is no simple solution to all these problems. Whatever procedure is adopted by the panel, some embarrassment will be caused to some oceanographers. The panel has given long consideration to the alternatives, and to the comments and criticisms put forward after publication of the first report. The recommendations of the panel are these.

- (1) That in future, chlorinity determinations should preferably be reported as such, and not converted to salinity estimates.
- (2) That when it is necessary to estimate salinity from chlorinity determinations, the equation $S\ \% = 1.80655\ Cl\ \%$ should be used rather than the Sørensen equation.
- (3) Salinity shall be redefined as a function of conductivity ratio.
- (4) An equation shall be computed from Dr. Culkin's measurements of chlorinity and conductivity ratio on the natural sea water samples held by the N.I.O. Samples from the Baltic and Black seas, and other low salinity areas, shall be included, and only samples collected near the surface shall be used. For the purpose of computing the equation, salinity shall be estimated from the original chlorinity determinations by the equation $S\ \% = 1.80655\ Cl\ \%$. Using the salinity estimates so obtained, and the corresponding conductivity ratios, an equation shall be computed by the method of least squares giving salinity as a function of conductivity ratio (R).
- (5) This equation shall constitute the definition of salinity.
- (6) The new tables connecting salinity and conductivity ratio shall be derived from this equation.

The procedure proposed will have these advantages. The salinity so defined can readily be determined by the conductivity method, which is the most precise method at present available. It is intended that Standard Sea Water shall be used as a conductivity standard, and will be certified as such (see section 5). Salinity so defined is conservative, and can be calculated by simple proportion either when mixing different sea waters, or when mixing sea water with fresh water. In the ocean range (salinity 32-39 ‰) the new salinity will agree within the normal precision of determination with earlier estimates based on chlorinity determination and the the Sørensen equation. The actual difference is zero at 35 ‰, and 0.0023 ‰ at 32 ‰ and 38 ‰.

The only area where these decisions may cause some problems is the Baltic Sea. Here salinity determined from conductivity measurements and the new tables will differ from earlier estimates, based on chlorinity, by about 0.02 ‰ at 11 ‰ and 0.025 ‰ at 6 ‰. This discrepancy is about the same as the precision of normal chlorinity determinations, and in view of the wide variations of salinity which prevail in the Baltic, the panel do not consider that such a change will cause much difficulty. We hope that the Baltic oceanographers will agree with our recommendations, as it is clearly desirable that the same nomenclature and definitions shall be used in all parts of the world.

Based on these decisions, the new tables have been prepared, and at the time of writing (February 1966) are ready for printing. The tables are based on determinations of chlorinity and conductivity ratio at 15°C (R_{15}) made on 135 samples of natural sea water, including samples from all oceans and from the Baltic, Black, Red and Mediterranean Seas. Salinity was estimated from chlorinity using

$$S \text{ ‰} = 1.80655 C_1 \text{ ‰}$$

and a fifth order polynomial computed by least squares giving salinity as a function of R_{15} , with a small correction to the constant term (+ 0.00018 ‰) to make $R_{15} = 1.0$ correspond with $S = 35 \text{ ‰}$.

$$S \text{ ‰} = -0.08996 + 28.2972R_{15} + 12.80832R_{15}^2 - 10.67869R_{15}^3 + 5.98624R_{15}^4 - 1.32311R_{15}^5$$

This equation constitutes the recommended definition of salinity.

Table Ia, based on the above equation, connects R_{15} with salinity, and is designed for use with thermostat salinity meters working at 15°. A second table (table Ib) gives corrections to conductivity ratio measured at any temperature between 10° and 30°, to give the equivalent value of R_{15} . This table is based on measurements of conductivity ratio at various temperatures with an Auto-Lab wide-range inductive salinometer. The correction (Δ_{15}) to bring conductivity ratio at temperature T° (R_t) to the ratio at 15° (R_{15}) is given by

$$\Delta_{15}(T) = R_{15} - R_t = 10^{-5} R_t (R_t - 1) (T - 15) [96.7 - 72.0R_t + 37.5R_t^2 - (0.63 + 0.21R_t^2)(T - 15)]$$

The values of Δ computed from this expression are considered to be accurate to within $\pm 0.05 \Delta$ for temperatures between 10° and 30°.

For the greater convenience of those using non-thermostat salinometers, a second set of tables (tables IIa and IIb) have been computed from the same data as tables Ia and Ib, but based on conductivity ratio at 20° (R_{20}) and covering the range of R_{20} from 0.1 to 1.2 (salinity about 3 to 42 ‰). These tables give

exactly the same values of salinity as Ia and Ib, but since most measurements on non-thermostat meters will be made at temperatures close to 20°, it will often be legitimate to neglect the small corrections given by table IIb, especially when salinities are near 35 ‰.

The tables will have brief introductions, indicating how they shall be used, and in accord with standard Unesco practice these will be in English, French, Russian and Spanish. The tables will be printed on separate sheets and bound in a loose-leaf binder with stiff covers, lettered "International Oceanographic Tables" in the four languages. The binder will be large enough to accommodate additional tables as they are available.

The panel think it necessary to point out that these new tables (on loose sheets, in stiff-cover binder) are not quite identical with the provisional tables referred to in section 2 (b). (bound in buff-coloured paper cover). A few copies of the provisional tables have been distributed for special purposes. As soon as the new tables are available, please destroy any copies you may have of the provisional tables. Sample sheets of the new tables are appended to this report (Appendix D).

4. FURTHER TABLES TO BE ISSUED

Further tables already under consideration for the series include:

- (a) effect of pressure on conductivity of sea water;
- (b) specific gravity from temperature and salinity;
- (c) chlorosity from chlorinity or salinity;
- (d) velocity of sound, from temperature, pressure, salinity;
- (e) salinity from refractive index.

The panel will welcome suggestions for additions or improvements to the tables. These may be sent to any member of JPOTS.

There was a discussion on the best form for specific gravity (σ_t) tables. The last panel report included samples of existing tables, and asked for recommendations. None had been received. After some debate, it was agreed that nomograms were to be preferred to tables, because more information could be conveyed on a page. Two nomograms are enclosed with this report (Appendix E) illustrating one possible format. Comments on this arrangement, and on possible alternatives, will be welcomed.

5. STANDARD SEA WATER AS A CONDUCTIVITY STANDARD

None of the conductivity salinometers at present in use measures conductivity directly, in reciprocal ohms per cm. All are designed to measure either as a ratio to a standard water, or are calibrated so as to read in salinity or chlorinity. Without exception they all need a sea water of known salinity for calibration purposes.

It has been customary for some years to use Copenhagen Standard Water as such a standard. To guard against any unforeseen variation in composition, for the last three years each new batch of standard water has been checked for relative conductivity at the N.I.O., using at least two earlier batches as standard in each case. No really significant variations have occurred during this time, that is the conductivity ratio has corresponded with the chlorinity within the normal precision of salinometers.

This procedure is not entirely satisfactory. It would be embarrassing if a batch of standard water was found to have a conductivity which did not correspond with the chlorinity. Also there is some evidence that conductivity of standard water may apparently increase slightly on prolonged storage, especially at elevated temperatures (see Park, 1964).

To overcome this problem the N.I.O. (as mentioned in section 2 (e)) have designed and built an apparatus for the direct measurement of the conductivity of each batch of standard water. This apparatus will also be used for a research programme to study the change in conductivity consequent on storage under different conditions, such as high temperature or mechanical oscillation as on board ship.

The apparatus measures the resistance of standard water contained in a fused silica cell of known dimensions, comparing this with a standard non-inductive resistor on a transformer bridge. The cell is held in a thermostat at 15°C. This temperature must be known to $\pm 0.001^\circ\text{C}$, which presents a difficult problem. The apparatus originally ordered for this function has proved unreliable, and a new quartz-crystal thermometer has been ordered. Unfortunately there is a delay in the delivery of this thermometer, but as soon as it is available the proving trials of the conductivity meter will be started.

It is hoped to have all new batches of standard water certified in conductivity (salinity) from about June of 1966. Used in combination with the new tables, which should be distributed before this time, all oceanographers will have a reliable and uniform basis for their salinity measurements.

REFERENCES

- Bather, J.M., & J.P. Riley (1953) J. Cons. int. Explo. Mer, 18, 277
Cox, R.A., F. Culkin, R. Greenhalgh & J.P. Riley (1962) Nature, 195, 518
Craig, H. (1961) Science 133, 1835
Forch, C., M. Knudsen & S.P.L. Sørensen (1902) Kgl. Danske Videnskab. Selskabs Skrifter, 7 Række, Naturvidensk. og Mathem. Afd. 12, 1
Hermann, F., (1951) J. Cons. int. Expl. Mer, 17, 223
Jacobsen, J.P. & M. Knudsen (1940) U.G.G.I. Assoc. Oceanogr. Phys. Publ. Sci. 7, 1
Park, K. (1964) Deep Sea Res. 11, 85
Thomas, B.D., T.G. Thompson & C.L. Utterback (1934) J. Cons. int. Expl. Mer, 9, 28

THE SPECIFICATION OF SALINITY ESTIMATORS

H. Charnock and J. Crease

National Institute of Oceanography

INTRODUCTION

Some of our colleagues are engaged in making precise measurements of the properties of sea water. They consult us, from time to time, about the statistical aspects of their observations and we have been asked for our views on the present status of the observations of chlorinity and conductivity ratio.

We have found it impossible to discuss this and allied problems usefully unless the words and symbols used are explicitly defined. The definitions we have found most satisfactory will be given and described in the hope that they will be considered by the joint ICES/IAPO/SCOR/Unesco Committee dealing with the problem.

TERMINOLOGY

The main need we have found is for the term "salinity estimator" to describe the relations now in use, or proposed, from which the "salinity" can be estimated from an observation of another variable, such as chlorinity or conductivity ratio.

In what follows a symbol without suffix (e.g. Cl) will represent a measured quantity (in this case chlorinity).

An estimator will be a precise mathematical function of a measured quantity and will be written as a symbol with a suffix. For instance, we shall write $Cl_3 = f_3(R)$ meaning that the estimator Cl_3 is exactly defined as a known function of the conductivity ratio R .

The word regression we shall use to describe a relationship between two variables which are highly correlated but not exactly related. Thus for example,

$$Cl = f_3(R) + \epsilon_3$$

is a regression. It means that in a particular set of observations of Cl and R , the values of Cl were statistically related (for example, in a least squares sense) by the function $f_3(R)$, the residual on a particular single observation being ϵ_3 . The residuals ϵ_3 will be in part experimental errors and in part due to small changes in the proportions of the major constituents of sea water. $Cl_3 = f_3(R)$ will be an estimator derived from the regression by dropping the residuals ϵ_3 .

THE DEFINITION OF SALINITY

At the second International Conference of ICES at Kristiania, 1901, it was resolved: that by salinity is to be understood the total weight in grammes of solid matter dissolved in 1,000 grammes of (sea) water.

According to Cox (1965) this definition in terms of total solids has not been revoked or superseded. However, there is throughout the literature the more usual definition, based on Sørensen's work; the salinity is the total amount of solid material in grammes contained in one kilogram of sea water when all the carbonate has been converted to oxide, the bromine and iodine replaced by chlorine and all organic material completely oxidized.

Neither the total solids nor the "Sørensen-salinity" can be measured with precision so that both definitions are in the nature of a concept. This is clearly preferable to any definition based solely on an experimental procedure, which could be altered by future developments in analytical technique.

We may note that, although salinity has not been defined in a form which would permit precision determination, no serious practical difficulty has arisen in its interpretation. Oceanographers have come to regard the salinity as related in an approximate way to the salt concentration and are accustomed to estimating it from measurements of other properties. It is with the definition of these salinity estimators that we are mainly concerned.

SALINITY ESTIMATORS

The measured variables which we shall use are:

- (a) The Sørensen-salinity (S) is the result obtained by following Sørensen technique for estimating the salinity as commonly defined.
- (b) The Chlorinity (Cl) is as usually defined, bearing an analogous relation to the chloride content as the Sørensen salinity bears to the dissolved solids. The silver nitrate used in the chlorinity determination is usually standardized relative to standard sea water whose chlorinity, in turn, is determined with reference to pure silver by the standard sea water service, Copenhagen.
- (c) The conductivity ratio (R) we define as the ratio of the electrical conductivity of a sample of sea water relative to that of a standard value of electrical conductivity, at a standard temperature. Until a suitable standard is available measurements have been made against a particular batch of standard sea water at a temperature of 15°C.

The salinity estimators (and the chlorinity estimators) based on measurements of these variables are now considered. Figure 1 is an attempt to illustrate the procedures.

- (1) S and Cl are defined quantities: apart from experimental error they estimate "salinity" and "chlorinity" respectively. One can write formally

$$S_1 = S \quad \text{and} \quad Cl_1 = Cl$$

to separate the estimate from the observation.

- (2) S₂ is a salinity estimator based on observations of S and Cl. Only one series of nine measurements is known (Sørensen 1901) and these provide the regression

$$S = f_2(Cl) + \epsilon_2 = 1.805 Cl + 0.03 + \epsilon_2$$

where ϵ_2 is a residual, in part experimental, of order 0.01 ‰.

The estimator is then defined as

$$S_2 \equiv f_2(C_1) \equiv 1.805 C_1 + 0.03$$

by dropping the residual ϵ_2 .

It is important to distinguish between salinity estimators such as S_1 and S_2 . S_2 is determined exactly by C_1 but S_1 is not. Differences will arise to the extent that the major constituents of sea water occur in different proportions.

(2A) Some workers have preferred to express the S/C_1 regression as

$$S = f_{2A}(C_1) + \epsilon_{2A} = 1.80655 C_1 + \epsilon_{2A}$$

so as to maintain consistency with the hypothesis of constant composition. This would not conflict with the original S determinations. It leads to a salinity estimator.

$$S_{2A} \equiv f_{2A}(C_1) \equiv 1.80655 C_1$$

Salinity estimates based on chlorinity titration (S_2) were for many years referred to as "salinities" without qualification. Since the titration was the most convenient method, and since the differences between S_1 and S_2 were in general smaller than the experimental error, no serious confusion arose.

The development of "salinometers" based on measurements of conductivity ratio created the need for a salinity estimator based on conductivity ratio.

(3) We seek a salinity estimator based on conductivity ratio

$$S_3 \equiv f_3(R)$$

The steps we propose are as follows (see Figure 1).

From a series of careful measurements of C_1 and R one writes a regression

$$C_1 = f_3(R) + \epsilon_3$$

leading to a chlorinity estimator

$$C_{12} = f_3(R)$$

This is then substituted into $f_{2A}(C_1)$ to get

$$S_3 \equiv f_{2A}(C_{12}) \equiv f_{2A}(f_3(R))$$

This will define a salinity estimator based on conductivity ratio which is consistent, within residual error, with S_1 and S_{2A} .

As a result of recent work observations are available from which the C_1/R regression can be specified. The present position of these observations will be discussed later.

Further estimators S_4 , S_5 etc. can be defined as needed. An estimator S_4 based on observations of chlorinity and density ratio is indicated on Figure 1. New estimators might also be based on the results of further series of observations of, say, S and C_1 . We have limited the notation S_2 , S_{2A} (S_{2B}) etc. to differing ways of expressing the same set of observations.

CONCLUSIONS

The procedure outlined defines the various salinity estimators and ensures consistency between them so far as is possible. Any one of them will be adequate for work where the highest accuracy is not needed.

However we must again state that the estimates S^1 , S^2 , S^3 etc. based on error-free observations on the same sea water may differ. Any differences which are established will pose an important oceanographic problem. It is therefore important that they shall be clearly defined.

<u>Basic Property</u>	<u>Dissolved Solids</u>	<u>Chlorinity</u>	<u>Conductivity</u>	<u>Density</u>
Estimators Salinity Chlorinity	$S_1 = S$	$S_2 = f_2(Cl)$ $S_{2a} = f_{2a}(Cl)$ $Cl_1 = Cl$	$S_3 = f_{2a}(Cl_2) = f_{2a}(f_3(R))$ $Cl_2 = f_3(R)$	$S_4 = f_{2a}(Cl_3) = f_{2a}(f_4(\sigma))$ $Cl_3 = f_4(\sigma)$
Regressions		$S = f_2(Cl) + \xi_2$ $S = f_{2a}(Cl) + \xi_{2a}$	$Cl = f_3(R) + \xi_3$	$Cl = f_4(\sigma) + \xi_4$
Measured Quantities	Sørensen salinity (S)	Chlorinity (Cl)	Conductivity Ratio (R)	Density Ratio (σ)

NOTES None of the basic properties has been satisfactorily measured.
 Variables without suffixes are observed quantities.
 Variables with suffix are estimated quantities.
 ξ represents the deviation of a single determination from a mean curve.
 S_1 and Cl_1 are the currently accepted definitions of salinity and chlorinity.

Figure 1 - Derivation of salinity estimators

A SALINITY ESTIMATOR BASED ON MEASUREMENTS
OF CONDUCTIVITY RATIO

by

H. Charnock and J. Crease

INTRODUCTION

This note gives a preliminary assessment of the material now available for the definition of a salinity estimator based on measurements of the conductivity ratio. It is written at the request of Dr. R.A. Cox and for the guidance of the Joint ICES/IAPO/SCOR/Unesco committee concerned with this subject. It should be read in conjunction with an accompanying paper on the specification of salinity estimators.

OBSERVATIONAL MATERIAL

1. Conductivity ratio

Observation on which the salinity estimator (S_3 in an earlier paper) may be based have been made on samples of sea water widely distributed over the ocean and from various depths.

The conductivity ratio (R) for each sample was determined by Dr. F. Culkin, National Institute of Oceanography, relative to standard sea water batch P31, at 15°C. The chlorinity of this batch is 19.375‰, and the corresponding value of salinity estimate $S_2 = 35.002$. A small correction was made to the primary measurements to get the conductivity ratio relative to standard sea water of $S_2 = 35.000$. This correction was based on earlier approximate measurements and will be consistent with the salinity estimator S_3 finally specified.

Repeat determination of conductivity ratio agreed within about 0.00005 provided the samples were drawn from sealed ampoules. No effect of storage was found.

Values measured on water from fully opened ampoules, from which chlorinity samples had been drawn, were greater by a few parts in 10^5 than those made earlier. As other workers have found an increase in R on opened samples we have not used these values further.

2. Chlorinities

All the chlorinities (Cl) were determined at the Department of Oceanography, University of Liverpool, in the first instance. These observations will be referred to as Liverpool I. Chlorinities for some of the samples have been re-determined at Liverpool (Liverpool II) and at the National Institute of Oceanography (N.I.O.). A small number of chlorinities were also measured at the Standard Sea Water Service, (Copenhagen).

Apart from this latter set, which will be discussed later, three overlapping sets of observations have been directly compared:

- | | |
|--|-------------|
| 1. Liverpool I and Liverpool II and N.I.O. | 102 samples |
| 2. Liverpool I and Liverpool II | 155 samples |
| 3. Liverpool I and N.I.O. | 173 samples |

In each case the chlorinity was expressed as:

$$C_1 = a_0 + a_1(R) + a_2(R^2) + a_3(R^3) + a_4(R^4) + \epsilon$$

where R is the conductivity ratio of the same water. The constants a_0 a_4 were chosen by a least square method (preliminary working having shown that curves of higher order than four did not reduce the r.m.s. deviation significantly). It is clear that the N.I.O. deviations are smaller than those of the Liverpool observations by a factor greater than 3. The standard deviation of the N.I.O. observation about the fitted curves is about 0.002‰. The standard deviation of the differences between Liverpool I and Liverpool II is about 0.006‰.

This indicates that the casual errors of the N.I.O. observations are significantly less than those of Liverpool I or Liverpool II or of their combination. Possible systematic differences are more difficult to assess but some indication can be obtained from the results of eight comparative measurements of chlorinity made at N.I.O. and at Copenhagen.

The N.I.O. observations are systematically less than those done at Copenhagen by only 0.0015 ± 0.0008 ‰. Though this latter difference is small it is statistically significant at the 1% level; the experimental error of N.I.O. replicates is about 0.001‰, and the corresponding figure for Copenhagen about 0.005‰.

The possibility that this systematic difference arises from the use of different batches of standard sea water is being investigated.

But it is clear that the N.I.O. determinations of chlorinity and conductivity ratio provide the best material currently available to us for the definition of salinity estimator S_3 , which in turn is based on C_1 .

THE C_1/R REGRESSION

Two possible definitions of C_1 are being considered, one using all the N.I.O. observations, the other using only those N.I.O. determinations made on surface samples.

It is desirable, though not essential, that $S_3 = 35.000$ when $CR = 1.00000$. This could most easily be achieved by adding a suitable constant (∓ 0.0005) to the C_1 values. This arbitrary adjustment can be partly justified by the results of the N.I.O./Copenhagen comparisons: it is not likely to be significant in routine work.

If there are significant differences between estimators based on surface and on all samples, we recommend that S_3 and C_1 should be defined by the regression, to sufficiently high order, of C_1 on CR , the values being those determined at N.I.O. on surface samples, each C_1 value being increased by a constant amount to ensure that $C_1 = 19.3740$ when $CR = 1.00000$.

Preliminary analysis shows that tables produced on this basis will differ from those which have already been constructed using a combination of N.I.O. conductivity ratios and Liverpool chlorinities (Unesco, undated). Although these differences are unlikely to exceed 0.005% in Cl₂ this is considerably greater than the standard error of a single N.I.O. or Copenhagen determination. It would be prudent in our opinion to withdraw these Unesco tables before they are widely circulated.

The earlier results suggested that S₄ (the salinity estimate based on observation of density ratio) is more closely related to S₃ (based on conductivity ratio) than to S₂ (based on chlorinity). The specification of S₄, in terms of density ratios and chlorinities determined at N.I.O., is now under consideration. In the meantime the earlier conclusion should be regarded as tentative until it is confirmed.

CONCLUSIONS

We recommend that the Committee issue, with a full account of their construction, tables by which salinity can be estimated from measurements of conductivity ratio.

These should, in our opinion, be based on measurements of chlorinity and conductivity ratio made at N.I.O.

Tables based on other measurements should be withdrawn and conclusions based upon them treated with reserve.

REPORT ON THE MEASUREMENT OF REFRACTIVE
INDEX OF SEA WATER SAMPLES

by

J.S.M. Rusby
National Institute of Oceanography

A Jamin interferometer has been used in a temperature controlled room to measure the difference in refractive index between test samples and Copenhagen sea water. It is possible to read fringe displacement to better than 1/30th fringe which would give a theoretical accuracy of 2 in the 7th decimal place for refractive index when using the 10 cm interferometer cell. This is equivalent to a change in salinity of 0.001‰. However the practical accuracy of the measurements is limited by the temperature stability of the optical parts of the apparatus, and also the errors introduced in handling the sea water and rinsing the cell.

To date measurements of the refractive index have been made at 20°C on 40 surface water samples with salinity values evenly spaced between 30 and 39‰. These samples were specially selected for their good agreement between the measured values of chlorinity and conductivity ratio in terms of salinity units. In order to identify the integral number of fringes involved it has been found necessary to plot a curve of the gradient of the chlorinity/refractive index curve versus chlorinity. Likewise the curve of the gradient of conductivity ratio/refractive index has also been plotted. Both these curves are linear over a large part of their length which indicate that the curves of chlorinity versus refractive index and conductivity ratio versus refractive index are exponential. In salinity units the gradients decrease from

$$\frac{\partial \mu}{\partial \text{Sal}} = 0.0001885 \text{ at } 30\text{‰}$$

$$\frac{\partial \mu}{\partial \text{Sal}} = 0.0001870 \text{ at } 40\text{‰}$$

Some preliminary calculations show that the standard deviation of the measured points from the best curve in a chlorinity versus refractive index plot is 0.005‰ (salinity units).

15°

$R_{15} \rightarrow S_{\infty}$

	0	1	2	3	4	5	6	7	8
0.97 00	33. 827	827	828	828	828	829	829	830	8
01	831	831	832	832	832	833	833	834	8
02	835	835	835	836	836	837	837	837	8
03	839	839	839	840	840	841	841	841	842
04	842	843	843	844	844	844	845	845	846
05	846	847	847	848	848	848	849	849	850
06	850	851	851	851	852	852	853	853	853
07	854	855	855	855	856	856	857	857	857
08	858	858	859	859	860	860	860	861	861
09	862	862	863	863	864	864	864	865	865
0.97 10	866	866	867	867	867	868	868	869	869
11	870	870	871	871	871	872	872	873	873
12	874	874	874	875	875	876	876	876	877
13	878	878	878	879	879	880	880	880	881
14	882	882	882	883	883	883	884	884	885
15	885	886	886	887	887	887	888	888	888
16	889	890	890	890	891	891	892	892	892
17	893	894	894	894	895	895	896	896	896
18	897	897	898	898	899	899	900	900	900
19	901	901	902	902	902	902	904	904	904
0.97 20	905	905	906	906	906	907	907	908	908
21	909	909	910	910	910	911	911	912	912
22	913	913	914	914	914	915	915	915	916
23	917	917	918	918	918	919	919	919	920
24	921	921	922	922	922	923	923	923	924
25	924	924	925	925	925	926	927	927	928
26	928	928	929	929	929	930	931	931	931
27	931	931	932	932	932	933	934	934	934
28	935	935	936	936	936	937	938	938	938
29	940	940	941	941	941	942	942	943	943
0.97 30	944	944	945	945	945	946	946	947	947
31	948	948	949	949	949	950	950	951	951
32	952	952	953	953	953	954	954	954	955
33	956	956	956	957	957	958	958	958	959
34	960	960	960	961	961	961	962	962	963
35	963	964	964	965	965	965	966	966	967
36	967	968	968	969	969	969	970	970	970
37	971	972	972	972	973	973	974	974	974
38	975	976	976	976	977	977	977	978	978
39	979	979	980	980	981	981	981	982	982
0.97 40	983	983	984	984	985	985	985	986	986
41	987	987	988	988	988	989	989	990	990
42	991	991	992	992	992	993	993	993	994
43	995	995	995	996	996	997	997	997	998
44	999	999	999	000	000	001	001	001	002
45	34. 002	003	003	004	004	004	005	005	006
46	006	007	007	008	008	008	009	009	009
47	010	011	011	011	012	012	013	013	013
48	014	015	015	015	016	016	017	017	018

SAMPLE SHEET - APPENDIX "D"
 The size of the type will be slightly reduced
 to correspond with the standard page size.

Table Ib

Tabla Ib

Таблица Ib

$$R_t + t^\circ \longrightarrow \Delta_{15}$$

$$\Delta_{15} + R_t = R_{15}$$

R_t	20°	21°	22°	23°	24°	25°	26°
0.85	-37	-44	-51	-57	-64	-70	-76
0.86	-35	-42	-48	-54	-60	-66	-71
0.87	-33	-39	-45	-51	-56	-62	-67
0.88	-31	-36	-42	-47	-52	-57	-62
0.89	-28	-34	-39	-44	-48	-53	-58
0.90	-26	-31	-36	-40	-44	-49	-53
0.91	-24	-28	-32	-36	-40	-44	-48
0.92	-21	-25	-29	-33	-36		-43
0.93	-19	-22	-26	-29	-32		-38
0.94	-16	-19	-22	-25	-		-33
0.95	-14	-16	-19	-21			-28
0.96	-11	-13	-15	-			-22
0.97	-8	-10	-11				-17
0.98	-6	-7	-			-6	-11
0.99	-3	-3				-5	-6
1.00	0				0	0	0
1.01	3			4	5	5	6
1.02	6			9	10	11	12
1.03				14	15	17	18
1.04			16	18	20	22	24
1.05			21	23	26	28	30
1.06		22	25	28	31	34	37
1.07		26	30	33	37	40	43
1.08	25	30	34	38	42	46	50
1.09	29	34	39	44	48	53	57
1.10	32	38	43	49	54	59	64
1.11	36	42	48	54	60	66	71
1.12	39	46	53	60	66	72	78
1.13	43	51	58	66	73	79	86
1.14	47	55	63	71	79	86	93
1.15	51	60	69	77	85	93	101
1.16	55	64	74	83	92	101	109
1.17	59	69	79	89	99	108	117
1.18	63	74	85	96	106	116	125
1.19	67	79	91	102	113	123	133

Sample Sheet - Appendix "D"

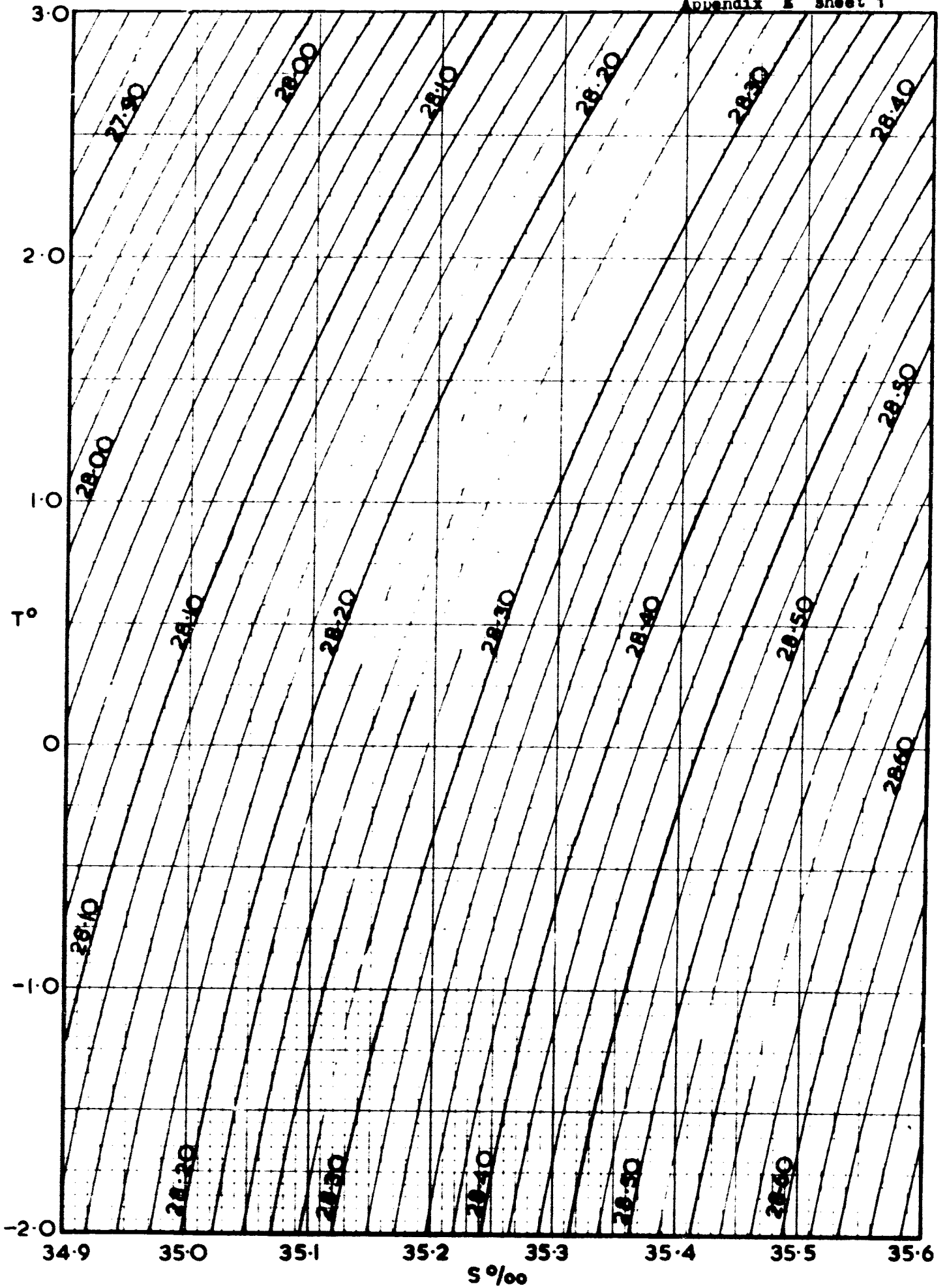

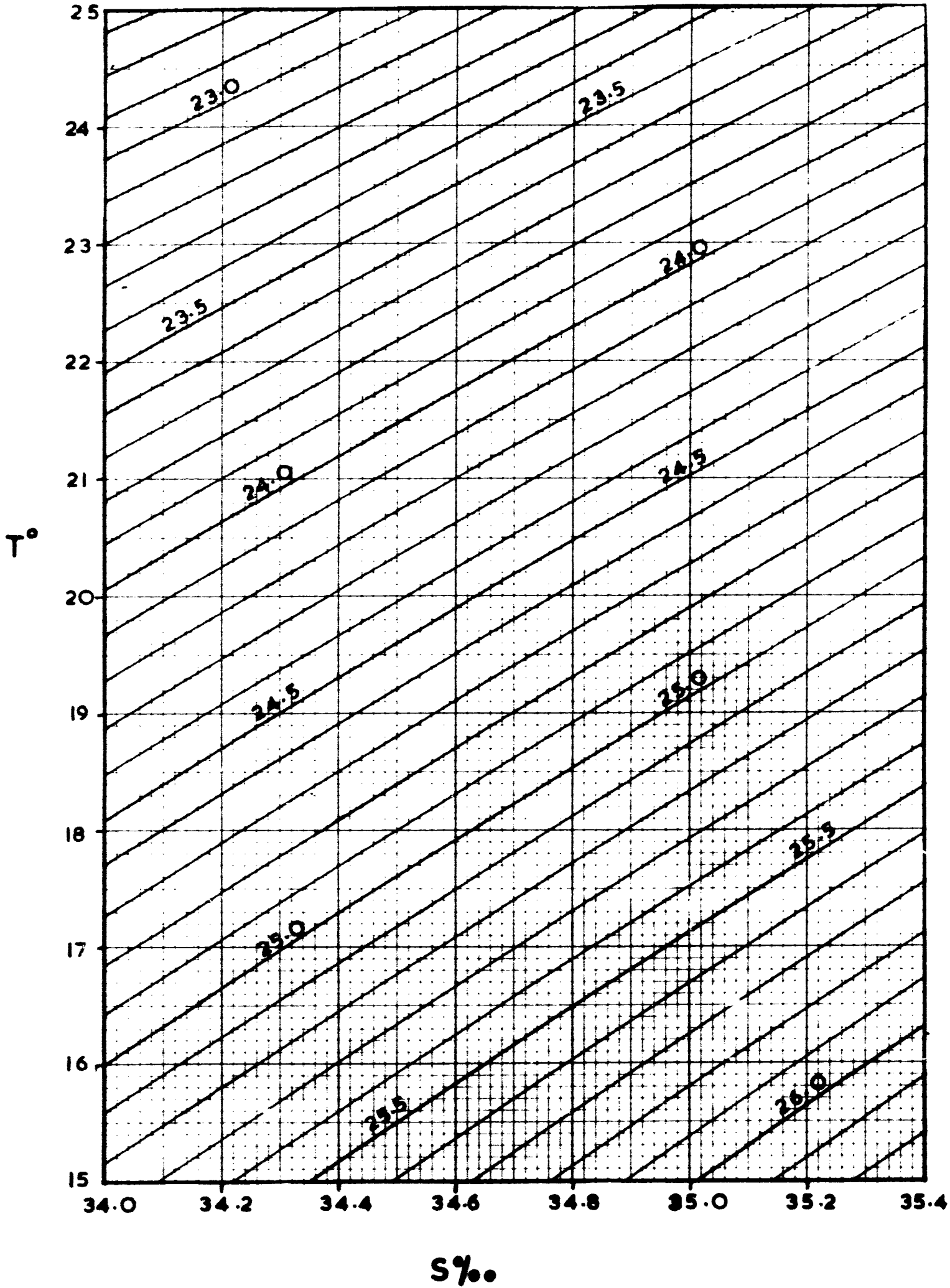

Unesco technical papers
in marine science
no. 8

**Third report of the Joint Panel on
Oceanographic Tables and Standards**

**Berne, 4-5 October 1967
sponsored by
Unesco, ICES, SCOR, IAPO**

Unesco

THIRD REPORT OF THE JOINT PANEL
ON OCEANOGRAPHIC TABLES AND STANDARDS

Berne, 4-5 October 1967

jointly sponsored by the

United Nations Educational, Scientific and Cultural Organization

International Council for the Exploration of the Sea

Scientific Committee on Oceanic Research

International Association of Physical Oceanography

The scientific views expressed here
are those of experts participating
in the work of the Panel and not
necessarily those of Unesco or other
sponsoring organizations.

The following members of the Panel attended the meeting in Berne, Switzerland, on 4 - 5 October 1967:-

Prof. Dr. G. Dietrich	- Federal Republic of Germany
Dr. N.P. Fofonoff	- U.S.A.
Mr. F. Hermann	- Denmark
Dr. G.N. Ivanov-Frantzkevich	- U.S.S.F.
Prof. Dr. W. Kroebel	- Federal Republic of Germany
Dr. F.H. Fisher	- U.S.A.
Dr. F. Culkin	- United Kingdom

Professor O. Saalen (Norway) sent apologies for his unavoidable absence.

Other participants of the meeting included:-

Mr. J. Crease	- United Kingdom
Prof. C. Eckart	- U.S.A.
Mr. G. Girard	- France
Dr. K. Grasshoff	- Federal Republic of Germany
Mr. M. Menache	- France
Prof. Y. Miyake	- Japan
Dr. J.S.M. Rusby	- United Kingdom
Mr. M.J. Tucker	- United Kingdom
Prof. W.S. Wooster	- U.S.A.
Dr. K.N. Fedorov	- UNESCO

In opening the meeting, Dr. Fedorov referred to the sad death of the Panel's Chairman, Dr. R.A. Cox, in March 1967, and the Panel observed one minute's silence in his memory. Mr. F. Hermann was then elected Chairman and Dr. F. Culkin was asked to act as Rapporteur.

Reports were given to the Panel on the progress of work in various laboratories. The following is a summary of these reports:-

Dr. G. Reusmann
Institut für Meereskunde
Niemannsweg 11
23 Kiel
Federal Republic of Germany

The following determinations have been carried out on more than 50 samples collected from different depths and different water masses in the Baltic:

Chlorinity
Specific gravity
Conductivity ratio
Salinity (gravimetric)
Major anions and cations

In this work it was considered necessary to equilibrate the samples with air before measuring conductivity because of the influence of the CO₂ system (as indicated by pH) on the conductivity. The most serious problem encountered has been that of temperature measurement. It has not been possible to have the Quartz Crystal Thermometer calibrated to better than 0.002°C because of instrumental instability. The results of the investigation suggest that some of the calcium in Baltic sea water is complexed by carbonate and sulphate and hence does not contribute as much to conductivity as was previously thought. It is intended to continue these investigations for several years in order to study the effect of stagnation periods. Then, from the final collection of data, a regional correction table with a simple chemical property as basis, will be prepared.

Dr. G.Y. Ryskin
Institute of Technical Physics
Academy of Sciences of the USSR
Leningrad
U.S.S.R.

Dr. Ivanov-Frantzkevich reported that determinations of density and thermal expansion of sea water were being carried out by Dr. Ryskin, using a float method which has an accuracy of $\pm 1 \times 10^{-6}$. (English translations of two articles by Dr. Ryskin are appended to this report as Annex I.) It is hoped to carry out measurements on a number of samples which were supplied by Dr. R.A. Cox.

Professor Dr. W. Kroebel
Institut für Angewandte Physik der Universität Kiel
Neue Universität, Haus 34
23 Kiel
Federal Republic of Germany

The following work is in progress:-

- 1) Measurement of conductivity as a function of pressure, temperature and salinity.

- 2) Measurement of ion mobility in sea water after the Hall effect.
- 3) Density as a function of sound velocity, temperature and conductivity with a view to arriving at explicit expressions.
- 4) The absolute determination of sound velocity as a function of pressure, temperature and salinity.

Dr. F.H. Fisher
Marine Physical Laboratory
Scripps Institution of Oceanography
San Diego, California 92152
U.S.A.

The following work on sea water is proposed:-

- 1) Density.
- 2) Sound velocity.
- 3) Electrical conductivity.
- 4) Dielectric constant.
- 5) Viscosity.
- 6) Transport numbers of individual ions.
- 7) Thermal expansion by the Rayleigh Benard method.
- 8) Specific heat at constant pressure.
- 9) Thermal conductivity

National Institute of Oceanography
Wormley, Godalming
Surrey
England

Absolute electrical conductivity of sea water
(Mr. M.J. Tucker and Mr. C. Clayson).

Mr. Tucker gave an account of some of the proposed modifications to the existing apparatus. These include a longer quartz cell and an interferometric method of

measuring the electrode displacement. The National Physical Laboratory have reported that the Quartz Crystal Thermometer can only be calibrated to 0.002°C because of instrumental instability but it is hoped to overcome this problem.

Specific gravity (Mr. M.J.M. McCartney).

Dr. Culkin reported that a series of measurements at 17.5°C , on sea waters covering the range 0 - 42‰, was almost complete. It is intended to carry out similar measurements at other temperatures, though some difficulties were expected at temperatures higher than 20°C . because of bubble formation on the float (Professor Kroebel suggested that this might be avoided by subjecting the sample to a short ultrasonic vibrational treatment before immersing the float.

Refractive index anomaly (Dr. J.S.M. Rusby).

The results of this investigation have recently been published (Deep-Sea Res. 1967, 14, 427-39) and will form the basis of an addition to the International Oceanographic Tables later this year (1967). Dr. Rusby discussed some of the problems involved in developing a routine method for obtaining salinity from refractive index anomaly at sea.

K. Schleicher and A. Bradshaw
Woods Hole Oceanographic Institution
Woods Hole, Massachusetts 02543
U.S.A.

Dr. N.P. Fofonoff reported that Schleicher and Bradshaw were making measurements of the thermal expansion of water under pressure. Measurements were also being made on sea water of salinity 35‰ over the temperature range -2°C . to 30°C . (2° intervals).

Mr. F. Hermann
Charlottenlund Slot
Charlottenlund
Denmark

Mr. Hermann presented his provisional report "The production and analysis of the chlorinity of a new primary standard sea water" and said that he hoped Professor D. Carritt would also determine the chlorinity of the new standard.

There was some discussion about the preparation of samples for specific gravity and electrical conductivity measurements. Mr. Menaché considered that the reference water for the specific gravity measurements should be free from dissolved gases, for the reasons outlined in the communication "Le problème du liquide de référence pour la détermination de la masse volumique de l'eau de mer", a copy of which is attached to this report as Annex II. Dr. Culkin and Dr. Grasshoff felt that, although such a reference liquid would have certain advantages they were outweighed by the difficulty of preparing and working with it. The Chairman pointed out that the difference in density between air saturated and air-free waters was only about 0.003 in 6_t .

Dr. Grasshoff stressed that it was essential in conductivity measurements that all samples should have the same pH. The simplest way of achieving this was to equilibrate the sample with air. The Chairman asked Dr. Grasshoff to prepare a report on the effect of change of pH on conductivity. This report will be published as a separate scientific paper.

Mr. Menaché recommended that several batches should be made of the specific gravity reference standard by the method of Cox and McCartney and that samples of each batch should be analysed for oxygen-18 and deuterium by several different laboratories. He also offered to make enquiries about having these analyses carried out.

The Chairman suggested that he, Mr. Menaché and Mr. Girard should assess the effect of natural variations in isotopic ratios on density.

Distribution of International Oceanographic Tables

Dr. Fedorov reported that UNESCO had distributed free copies of the new Tables to approximately 1000 laboratories. Copyright had been granted to the USSR authorities to reproduce and distribute further 2000 copies for internal use. The Bissett-Berman Co. were now including copies of the new Tables in the handbook of their inductive salinometer. Misprints had been noted in the Introduction to the International Oceanographic Tables and it is intended to correct these in new introductory pages which will be issued to all users of the Tables. Dr. Fedorov said that the refractive index tables were now being printed and should be ready by the end of 1967. Professor Wooster suggested that announcements of the issue of additional tables should be made in oceanographic journals and Dr. Fedorov said that this would be done. The Panel then discussed future additions to the Tables.

Additions to the International Oceanographic Tables

Dr. Grasshoff reviewed the literature on the solubility of oxygen in seawater and concluded that the recently published figures by E.J. Green and D.E. Carritt were the most reliable. The Sub-Committee on Chemical Analysis of Sea Water intends to recommend to the Hydrographic Committee of ICES that this data should be used as the basis of new tables of oxygen saturation of sea water. The Panel resolved that, if its recommendation were accepted, Dr. Green and Dr. Grasshoff should be asked to prepare the tables, which would then be distributed by UNESCO as a new instalment of the International Oceanographic Tables.

There was some discussion on the desirability of publishing chlorosity tables. Professor Wooster considered them unnecessary but other members of the Panel felt that they would be very useful to laboratories which had no computing facilities. It was decided that a Sub-Committee consisting of the Chairman, Mr. Menaché and Dr. Grasshoff should prepare the necessary tables.

The following is a list of proposed future additions to the International Oceanographic Tables:-

- 1) Refractive index anomaly/salinity (Dr. J.S.M. Rusby)
- in print.
- 2) Oxygen saturation values for sea water (Dr. E.J. Green, Massachusetts Institute of Technology, and Dr. K. Grasshoff)
- ready for printing in 1967 if ICES accept the recommendation that the data published by Green and Carritt should be used.
- 3) Chlorosity from chlorinity or salinity (Mr. F. Hermann, Mr. Menaché and Dr. K. Grasshoff) - ready early in 1968.

- 4) Specific gravity from salinity or conductivity.
(Mr. M.J.M. McCartney and the late Dr. R.A. Cox,
NIO) - probably late 1968.
- 5) Absolute electrical conductivity of sea water
(Mr. M.J. Tucker, Mr. C. Clayson and the late
Dr. R.A. Cox, NIO) - probably 1969.

In the concluding session Professor Wooster asked for a statement on present knowledge of the equation of state of sea water and the Panel was addressed by Professor Eckart and Dr. Fofonoff. It was suggested that a monograph should be written on the equation of state of sea water to clarify the situation and to show the oceanographer which measurements are still needed. Professor Eckart said he was working on such a monograph.

Dr. Fedorov said that it had been the intention of Dr. R.A. Cox to write a monograph on salinity of sea water and its determination, to be published by UNESCO. The Panel felt that the monograph should still be written, preferably by someone from NIO, and Mr. Grease and Dr. Culkin agreed to collaborate on this.

Changes in Membership

Professor G. Dietrich, a founder member and former Chairman of the Panel, expressed his wish to resign and proposed that he should be replaced as SCOR representative by Dr. K. Grasshoff.

Mr. F. Hermann proposed that ICES should be asked to nominate Dr. F. Culkin as their representative, to replace the late Dr. R.A. Cox.

Dr. Fedorov proposed that Mr. Menaché should be a UNESCO representative on the Panel. Mr. Menaché was also asked to represent the Panel on the IUGG Committee on Critical Data.

The revised list of the Panel's members is given as Annex III.

A draft resolution was then submitted by the Panel to IAPSO requesting approval of the new definition of salinity in terms of electrical conductivity. It was understood that the definition may be subject to modification when the effect of pH on conductivity is known. The General Assembly of IAPSO * approved the above draft. The approved Resolution is given in Annex IV.

* Now IAPSO - International Association of Physical Sciences of the Ocean.

Translations into English
of papers by B. Konstantinov, G.Ia. Kyskin and others
on methods of measurements of the coefficients of
expansion and compressibility.

Zhurnal Tekhnicheskoi Fiziki, 28, No. 8, 1740-1747, 1958.

Translation from - *Soviet Physics - Technical Physics*, 3, (8), 1604-1611, 1958.

ИЗМЕРЕНИЕ КОЭФФИЦИЕНТОВ РАСШИРЕНИЯ NaCl, LiF, KCl, KBr
ФЛОТАЦИОННЫМ МЕТОДОМ

Б. П. Константинов, Э. Н. Ефремова и Г. Я. Рыскин

MEASUREMENT OF THE COEFFICIENTS OF EXPANSION
OF NaCl, LiF, KCl and KBr BY THE FLOTATION METHOD

B. P. Konstantinov, Z. N. Efremova and G. Ia. Ryskin

The technique of the measurement of coefficients of expansion by the flotation method is described and the results of measurements for NaCl, KCl, KBr and LiF are given. The values obtained are in close agreement with the corresponding data of x-ray and interferometer measurements. The error of the method does not exceed 0.5-1.0%.

The coefficients of thermal expansion of NaCl, KCl, KBr and LiF have been repeatedly measured by several methods. The results of the measurements are in agreement within the limits of error of the measurements, which are about 1% for interferometer and x-ray methods and 3-5% for dilatometer measurements. Evidently, the interferometer and the x-ray data are to be regarded as being the most reliable.

In a recently published communication [1], a new flotation method was proposed for measuring the coefficients of volumetric expansion, γ_c , of crystals. Estimation of the error of this method showed that the error of a single measurement ought not to exceed 1% of the measured magnitude. The paper did not, however, give data on the experimental confirmation of the method.

The present paper describes the technique of the measurement of γ_c by the flotation method and gives the results of measurements for NaCl, KCl, KBr and LiF.

The flotation method of measuring the coefficient of volumetric expansion γ_c is based on the accurate measurement of the difference in the densities of a float of known coefficient of expansion and of the investigated crystal. It is necessary to measure directly merely the flotation temperatures of the float and crystal in the two flotation liquids and the coefficients of expansion of these liquids.

The mean value of $\bar{\gamma}_c$ in the temperature range $T_{1c}-T_{2c}$ is calculated from these data by means of formula (1)

$$\bar{\gamma}_c = \frac{\bar{\delta}_{2llq}(T_{2c}-T_{2f}) - \bar{\delta}_{1llq}(T_{1c}-T_{1f}) + \bar{\delta}_f(T_{2f}-T_{1f})}{\bar{\rho}_c(T_{2c}-T_{1c})} \quad (1)$$

where T_{1f} and T_{1c} are the flotation temperatures of float and crystal in the first liquid and T_{2c} and T_{2f} are the corresponding values for the second liquid; $\bar{\delta}_f$, $\bar{\delta}_{2llq}$, $\bar{\delta}_{1llq}$ are the mean density variations for a temperature variation by 1°C: $\bar{\delta}_f$ - for the float in the range $T_{2f}-T_{1f}$; $\bar{\delta}_{1llq}$ for the first liquid in the range $T_{1c}-T_{1f}$; $\bar{\delta}_{2llq}$ for the second liquid in the range $T_{2c}-T_{2f}$; $\bar{\rho}_c$ is the mean value of the density of the crystal in the temperature range $T_{2c}-T_{1c}$.

Experimental Setup

The measurement of $\bar{\gamma}_c$ consists of the following operations: 1) growing the crystals of the investigated compound; 2) preparing the floats; 3) preparing the flotation mixtures; 4) measuring the flotation temperatures of crystals and float; 5) determining $\bar{\delta}_{llq}$ of the flotation mixtures.

The following is a description of the operations enumerated.

1. Production of crystals. For the measurement of the coefficient of expansion by the flotation method, any crystals are suitable, either natural or artificial, provided they have no inclusions of foreign matter and no cracks. In our measurements we used crystals grown from melts of the well purified compounds. The degree of purity was checked by spectrum analysis. The crystals were grown on the end of a platinum point and had the form of hemispheres 2-4 mm in diameter.

2. Preparation of the floats. The floats were made from fused quartz. For measuring γ_c of NaCl and KCl, the density of which is less than that of quartz, the floats used contained air bubbles, and for measuring the coefficients of expansion of KBr and LiF, floats with platinum fused internally in them were used.

The technique of preparing the floats differs little from the methods described in the literature for the preparation of floats used in the analysis of the isotopic constitution of water [2]. The accurate adjustment of the density of the floats was effected by etching them in a saturated aqueous solution of ammonium fluoride. By comparing from time to time the flotation temperature of the floats and corresponding crystals, it was possible to obtain floats, the density of which differed from the density of the given crystal by an amount which was as small as desired. It should be noted that when the floats are etched in a solution of NH_4F , their surface remains smooth and bright.

3. Preparation of the flotation mixtures. A liquid having at the given temperature a density equal to the density of the investigated crystal was prepared by mixing two components, one of which had a density greater than that of the crystal and the other a density less than that of the crystal. The density of such a flotation mixture must remain constant in the limits of accuracy of the flotation measurements (0.2-0.5%), at least for a time sufficient to permit measurement of the flotation temperature. To satisfy this fundamental requirement, the following conditions must be satisfied: 1) the solubility of the crystal investigated must be negligibly low; 2) the components of the mixture must be chemically stable in the temperature range investigated; 3) evaporation of the liquid must be small and not accompanied by any change in density.

The preparation of liquids satisfying the conditions enumerated usually does not give rise to any difficulties. We used mixtures of bromoform and ethylene bromide, bromoform and n-hexanol, and others. The bromoform, ethylene bromide, and other halogen derivatives were dehydrated by means of phosphorus pentoxide, and the alcohols by boiling with shavings of metallic calcium under a reflux condenser. After this treatment, the liquid was distilled in a vacuum (5-15 mm Hg). The distilled reagents and mixtures were kept in stoppered vessels in desiccators with fused KOH.

4. Measurement of the flotation temperature. The crystals and floats were lowered into a measuring test tube containing the flotation mixture in an amount of 1.5-2 mm³. The test tube was closed with a ground-glass stopper and placed in the socket of a thermostat. The temperature in the thermostat was regulated with an accuracy of up to 0.002°C by means of a laboratory autotransformer by varying the current passing through the winding of an electrical heating element immersed in the thermostat.

The movements of floats and crystals were observed through a microscope (MIR) fixed to a stand, set up in front of the thermostat. Fixed to the same stand was a microscope for reading a Beckmann thermometer graduated in 0.01°C.

The actual measurement of the flotation temperature was carried out as follows. The temperature in the thermostat was raised and lowered continuously, so that the crystal (float) correspondingly sank and floated. The interval between the temperatures of floating and sinking was gradually narrowed until it was 0.002-0.004°C. The temperature corresponding to the mean of the last interval was equal to the flotation temperature of the crystal (float) with an error not exceeding half the interval.

5. Determination of $\bar{\beta}_{11q}$ of the flotation mixtures. The temperature coefficient of the density of the flotation mixtures was determined by the pycnometer method. A quartz pycnometer with a capacity of 24 cc and a capillary 0.1 mm in diameter was used for this purpose. The pycnometer was filled and emptied by means of a fore-vacuum pump.

For measuring $\bar{\beta}_{11q}$ in the range $T_1 - T_2$ where $T_1 < T_2$, the pycnometer was filled with the investigated liquid at a temperature below T_1 and then placed in a thermostat heated to T_1 . The temperature in the thermostat was kept constant with an accuracy of $\pm 0.002^\circ\text{C}$ and was measured by means of a very accurate thermometer

(of the Beckmann type) graduated in 0.01°C.

The liquid escaping from the pycnometer during the heating of the latter was removed from the end of the capillary by means of filter paper. Ten to fifteen minutes after the escape of liquid had stopped and its meniscus stood at the level of the capillary tip, the pycnometer was removed from the thermostat, washed with distilled ethyl alcohol from a wash bottle, and weighed on an analytical balance. The accuracy of weighing was ± 0.2 mg.

In this way, the weight of pycnometer with liquid was determined, corresponding to several temperatures within the range $T_1 - T_2$, separated from each other by about 1°C. At the same time, the range of measurement $T_1 - T_2$ was selected so as to comprise the points T_{2c} and T_{1f} of interest to us and so that all the temperature variations could be measured on one thermometer, i.e., within the limits of 5°C.

The pycnometer measurements of $\bar{\beta}_{liq}$ were very long and tedious. In this connection, it should be noted that in a number of cases, the value of $\bar{\beta}_{liq}$ for the mixtures can be calculated from the values of β_1 and β_2 given in the tables for the pure components of which the mixture consists. Calculation is based on the assumption that β is additive and is carried out according to the formula

$$\bar{\beta}_{mix} = \beta_1 x + \beta_2 (1 - x), \quad (2)$$

where x is the proportion by volume of the first component of the mixture.

Experimental confirmation of formula (2) for mixtures of bromoform and ethyl bromide showed that within the limits of accuracy of the measurement of β (0.5%), the calculated values agreed with the experimental values.

Another method of determining β will be described below, the two-float method, giving a considerable reduction in the number of pycnometer measurements.

II. Results of the Measurements

Sodium chloride. The crystals of NaCl were grown from a melt of the salt NaCl, mark "khch" (chemically pure). The coefficient of expansion of a natural crystal of NaCl (rock salt) was measured at the same time. The basic flotation liquid used was ethylene bromide, the density of which coincides with the density of NaCl at about 26.4°C. Bromoform was added to it for measurements at higher temperatures, and n-hexanol for measurements at lower temperatures.

The temperature coefficient of the density of pure ethylene bromide, measured by the pycnometer method and in the temperature range 28-25°C, was found to be

$$\beta_{liq} = 2.091 \cdot 10^{-3} \text{ g.cm}^{-3} \cdot \text{deg}^{-1}.$$

The measurement of β of other flotation liquids required for the flotation measurements of the coefficient of expansion of NaCl was carried out by the two-float method. The essence of this method consists in the following. The difference in the flotation temperatures of two quartz floats in the investigated liquid and in a liquid for which the value of β is known, for example ethylene bromide, is measured. Since the difference in density $\Delta\rho$ of the two floats is constant, it is evident that

$$\beta_x \Delta T_x = \beta \Delta T, \quad (3)$$

where ΔT_x and ΔT are the differences in the flotation temperatures of the two floats in the investigated liquid and in pure ethylene bromide. From this we find the temperature coefficient of the density of the investigated liquid

$$\beta_x = \frac{\Delta T}{\Delta T_x} \beta. \quad (4)$$

For ΔT equal to 3-4°C, the relative accuracy of the measurement of β_x by the two-float method is about 0.1%, if the true value of β is known. The results of the measurements of all the quantities (except β_f) required for the calculation of γ_c of the crystals according to formula (1) are given in Table 1. In the designation of the

TABLE 1

Results of Measurements of the Coefficient of Expansion of NaCl

Specimen	Composition of flotation mixture	$T_c, ^\circ\text{C}$	$T_f, ^\circ\text{C}$	$\beta_{\text{liq}} \cdot 10^3, \frac{\text{g}}{\text{cm}^3} \times \frac{1}{^\circ\text{C}}$	$\beta_{\text{liq}}, \frac{\text{g}}{\text{cm}^3} \times \frac{1}{^\circ\text{C}}$	$\rho_c, \frac{\text{g}}{\text{cm}^3}$	$\gamma_c, \frac{1}{^\circ\text{C}}$
Crystal No. 1 grown from the melt	$\text{C}_2\text{H}_4\text{Br}_2 + n\text{-C}_6\text{H}_{11}\text{OH}$	22.602	23.973	2.073	2.166	2.164	120.3
		33.322	33.359	2.116	2.163		
	$\text{C}_2\text{H}_4\text{Br}_2 + \text{CHBr}_3$	22.599	23.973	2.073	2.166	2.164	120.3
		33.427	33.464	2.116	2.163		
Crystal No. 2	$\text{C}_2\text{H}_4\text{Br}_2 + n\text{-C}_6\text{H}_{11}\text{OH}$	33.325	33.359	2.116	2.166	2.164	121.3
		22.592	23.973	2.073	2.163		
	$\text{C}_2\text{H}_4\text{Br}_2 + n\text{-C}_6\text{H}_{11}\text{OH}$	22.594	23.973	2.116	2.166	2.164	120.5
		33.421	33.464	2.073	2.163		
Rock salt	$\text{C}_2\text{H}_4\text{Br}_2 + n\text{-C}_6\text{H}_{11}\text{OH}$	33.304	33.359	2.116	2.166	2.164	120.6
		22.582	23.973	2.073	2.163		
	$\text{C}_2\text{H}_4\text{Br}_2 + n\text{-C}_6\text{H}_{11}\text{OH}$	22.582	23.973	2.116	2.166	2.164	120.0
		33.403	33.464	2.073	2.163		
Crystal No. 1	$\text{C}_2\text{H}_4\text{Br}_2 + \text{CHBr}_3$	33.322	33.359	2.116	2.163	2.161	121.1
		49.781	47.838	2.156	2.159		
		33.427	33.464	2.116	2.163		
Crystal No. 2	$\text{C}_2\text{H}_4\text{Br}_2 + \text{CHBr}_3$	49.772	47.830	2.156	2.159	2.161	121.1
		33.325	33.359	2.116	2.163		
		49.776	47.838	2.156	2.159		
Rock salt	$\text{C}_2\text{H}_4\text{Br}_2 + \text{CHBr}_3$	33.421	33.464	2.116	2.163	2.161	121.3
		49.771	47.830	2.156	2.159		
		33.304	33.359	2.116	2.163		
Rock salt	$\text{C}_2\text{H}_4\text{Br}_2 + \text{CHBr}_3$	49.751	47.838	2.156	2.159	2.161	121.2
		33.403	33.464	2.116	2.163		
		—	—	2.156	2.159		
Crystal No. 1	$\text{C}_2\text{H}_4\text{Br}_2 + \text{CHBr}_3$	33.322	33.359	2.116	2.163	2.159	121.5
		63.388	59.853	2.185	2.155		
Crystal No. 2	$\text{C}_2\text{H}_4\text{Br}_2 + \text{CHBr}_3$	33.325	33.359	2.116	2.163	2.159	121.4
		63.388	59.853	2.185	2.155		
Rock salt	$\text{C}_2\text{H}_4\text{Br}_2 + \text{CHBr}_3$	33.304	33.359	2.116	2.163	2.159	121.2
		63.357	59.853	2.185	2.155		

columns corresponding to these quantities, the indices "1" and "2" have been omitted. Of the two lines arranged in pairs, the values given in the first line correspond to the index "1" and those in the second line to the index "2".

The values of $\bar{\rho}_c$ given in the penultimate column of Table 1 were assumed equal to

$$\bar{\rho}_c = \frac{\rho_{1c} + \rho_{2c}}{2} = \frac{\rho_{1\text{liq}} + \rho_{2\text{liq}}}{2}$$

To find the temperature coefficient of density of the float we made use of the values given in the "International Critical Tables" for the coefficient of expansion of fused quartz: $\gamma_f = 1.1 \cdot 10^{-6} \text{ deg}^{-1}$ at 0°C and $1.5 \cdot 10^{-6} \text{ deg}^{-1}$ at 50°C .

It is obvious that $\beta_f = \gamma_f \rho_f$, where ρ_f is the density of the float. The floats and flotation mixtures were selected so that in one liquid the difference $T_{1c} - T_{1f}$ was nearly zero.

If this condition is observed, there is no need to measure $\bar{\beta}_{1\text{liq}}$ and the error in the measurement of γ_c is reduced. If the difference ($T_{1c} - T_{1f}$) was not equal to zero but did not exceed 0.1°C , it was assumed in the calculation of γ_c that $\bar{\beta}_{1\text{liq}} = \bar{\beta}_{2\text{liq}}$.

The results obtained show that the divergence of the values of γ_c , calculated from different measurements

TABLE 2

Coefficient of expansion of KCl and KBr

Salt	Composition of flotation mixture	T _c , °C	T _f , °C	$\frac{\beta_{\text{liq}} \cdot 10^3}{\text{cm}^3 \text{ deg}}$	ρ_{liq} , g/cm ³	ρ_c , g/cm ³	γ_c , deg ⁻¹
KBr	CHBr ₃ + C ₂ H ₄ Br ₂ the same	11.016	11.016	—	2.755	2.7515	117.0
		29.685	27.354	2.546	2.748		
KBr	CHBr ₃ + C ₂ H ₄ Br ₂ CHBr ₃ + n-C ₈ H ₁₇ OH	11.016	11.016	—	2.755	2.7515	116.6
		29.162	26.881	2.522	2.748		
KBr	CHBr ₃ + C ₂ H ₄ Br ₂ the same	11.016	11.016	—	2.755	2.7485	117.6
		49.664	44.872	2.581	2.742		
KBr	CHBr ₃ + CH ₂ Br ₂ CHBr ₃ + n-C ₈ H ₁₇ OH	11.016	11.016	—	2.755	2.7485	117.3
		49.632	44.845	2.578	2.742		
KCl	C ₂ HBr ₂ + C ₂ H ₁₁ Br the same	27.855	27.855	2.01	1.984	1.982	109.1
		48.314	46.125		1.980		
KCl	Dibromopropane (1,3) the same + CHBr ₃	14.581	14.74P	1.797	1.9894	1.9888	108.7
		19.836	19.377				

for the same crystal, do not exceed 0.7%, i.e., they confirm, in the case of NaCl, the estimation of the accuracy of the flotation method made in reference [1].

The results we have obtained do not confirm the difference observed by Srinivisan [3] between the coefficient of expansion of rock salt and crystals of NaCl grown from the melt. The temperature dependence of γ_c , according to our data, is less pronounced than would follow from Srinivisan's empirical formulas for synthetic crystals

$$\alpha = 39.2 \cdot 10^{-6} + 3.9 \cdot 10^{-8} t^\circ \text{C} \quad (5)$$

and for rock salt

$$\alpha = 40.7 \cdot 10^{-6} + 3.3 \cdot 10^{-8} t^\circ \text{C}, \quad (6)$$

where α is the coefficient of linear expansion.

Potassium chloride and potassium bromide. All the data required for calculating the coefficients of expansion of KCl and KBr and the results of the measurements are given in Table 2. As in the case of NaCl, the discrepancies between the repeated measurements do not exceed 0.5% and are in agreement with the estimation of the accuracy of the method given in [1]. In the measured temperature ranges, within the limits of accuracy of the flotation method, no temperature dependence of the coefficients of expansion was observed.

Lithium fluoride. The measurements were made on two crystals grown from melts. Mixtures of bromoform and ethylene bromide were used as flotation liquids.

The pycnometer method was used for determining the density and temperature coefficient of the density for the mixture in which the flotation temperature of LiF crystals was equal to 29.19°C. In the temperature range 28-30°C, the value of $2.464 \cdot 10^{-3} \text{ g.cm}^{-3} \cdot \text{deg}^{-1}$ was obtained for β .

The measurement of β for the other flotation liquids was made by the two-float method. Unlike the measurements for NaCl, KCl and KBr, the flotation temperatures of LiF were measured in previously evacuated and sealed ampoules. This eliminated fluctuations in the flotation temperatures due to partial evaporation of the liquid, and improved the reproducibility of the results of the measurements. The ampoule containing the liquid, crystals and floats was cooled in liquid air, evacuated by means of a fore-vacuum pump, and then sealed.

The results of measurements of the coefficient of expansion of LiF at different temperatures are given in Table 3. In this series of measurements, special experiments were made to confirm the fundamental condition of

TABLE 3

Coefficient of expansion of LiF

Comp. of flotation mix.	Specimen	T _c , °C	T _f , °C	β _{liq} · 10 ³ , g/cm ³ · deg	ρ _{liq} , g/cm ³	ρ _c , g/cm ³	γ _c , deg ⁻¹	γ, according to Sharma's formula
Bromoform and ethylene bromide	Crystal 1	18.00	17.23	2.413	2.639	2.6	96.7	102.8
		29.19	27.284	2.464	2.636			
	Crystal 1	18.008	17.231	2.443	2.639	2.6375	96.7	102.8
		29.19	27.284	2.464	2.636			
	Crystal 2	18.083	17.23	2.443	2.639	2.6375	96.04	102.8
		29.19	27.284	2.464	2.636			
	Crystal 2	18.090	17.233	2.43	2.639	2.6375	96.05	102.8
		29.19	27.284	2.464	2.636			
	Crystal 1	29.190	27.284	2.464	2.636	2.634	100.4	103.6
		44.525	41.037	2.496	2.632			
	Crystal 1	29.193	27.284	2.464	2.636	2.634	100.4	103.6
		44.525	41.037	2.496	2.632			
	Crystal 1	44.525	41.037	2.496	2.632	2.630	104.6	104.7
		55.284	50.674	2.520	2.6288			
	Crystal 1	44.530	41.035	2.496	2.632	2.630	104.62	104.7
		55.284	50.674	2.520	2.6288			
	Crystal 2	44.561	41.037	2.496	2.632	2.630	104.4	104.7
		55.284	50.674	2.520	2.6288			
Crystal 2	44.565	41.039	2.496	2.632	2.630	104.4	104.7	
	55.284	50.674	2.520	2.6288				
Crystal 1	55.284	50.674	2.520	2.6288	2.627	108.3	105.8	
	70.064	63.888	2.554	2.626				
Crystal 1	55.290	50.675	2.520	2.6288	2.627	108.26	105.8	
	70.064	63.888	2.554	2.626				

the applicability of the method: variations in flotation temperatures on transferring the crystals from one liquid to another are due solely to temperature expansion of liquid and crystal and not to other causes, which could produce a variation in density of the crystal (chemical reaction with the liquid, solution, cracks, etc.).

For this purpose, after each measurement in a given liquid, the crystals and floats were transferred to the same control liquid (T_c = 29.19°C).

Repeated measurements showed that in this control liquid, the different (T_c - T_f) for a given crystal and float was constant within the limits of accuracy of the flotation measurements, irrespective of whether the previous measurements had been made at high temperatures (up to 75°C) or low temperatures (10°C). The results given in Table 3 confirm the existence of an appreciable temperature dependence of the coefficient of expansion of lithium fluoride, as was obtained by Adenstedt [4] and Sharma [5]. According to our data, however, this dependence is more pronounced than follows from Sharma's empirical formula

$$\alpha = 0.043376 + 0.072054t + 0.0104885t^2 \quad (7)$$

where α is the coefficient of linear expansion of LiF.

For comparison, the values of γ_c, calculated according to Sharma's formula, are given in the last column of Table 3.

The causes of the discrepancies between the corresponding values of γ_c, obtained by our flotation method and Sharma's interferometer method, have not yet been explained.

Comparison with Data in the Literature

Table 4 gives the results of flotation measurements of the coefficients of expansion of NaCl, KCl, KBr and LiF compared with the data of other authors. The discrepancies with recent x-ray and interferometer measurements do not, as a rule, exceed 2-3%.

TABLE 4

Results of Measurements of $\bar{\gamma}$ for Some Halides

	Method	Temperature range	\bar{T} , °C	γ_c , deg ⁻¹
NaCl				
Our data, 1957	Flotation	22.6 - 33.3	27.9	120.3
Fiseau [6], 1867	Flotation	33.3 - 49.8	41.6	121.2
Henglein [7], 1925	Interferometer	15 - 65	40	120
Straumanis, Levins [8], 1938	Dilatometer	0 - 50	25	115
Srinivisan [3], 1955	x-Ray	18 - 67	43	121.5
	Interferometer		20	120
KCl				
Our data	Flotation	27.9 - 48.3	32.1	109.1
Fiseau [6], 1867	Interferometer	15 - 65	40	114
Henglein [7], 1925	Dilatometer	0 - 50	25	110
Glover [9], 1954	x-Ray		40	108
Srinivisan [3], 1955	Interferometer		40	112.7
KBr				
Our data, 1957	Flotation	11 - 29	15	116.8
Fiseau [6], 1867	Flotation	11 - 49.6	30.3	117.5
	Interferometer	15 - 65	40	126
Henglein [7], 1925	Dilatometer	0 - 50	25	118
Gott [10], 1942	x-Ray	18 - 100	59	116.4
Connell, H. Martin [11], 1951	x-Ray	18 - 100	59	116.4
LiF				
Our data	Flotation	17.2 - 27.3	22.3	96.4
Straumanis, Levins, Karlsons [8], 1938	Flotation	27.3 - 41.0	34.2	100.5
	Flotation	44.5 - 55.3	49.9	104.5
	Flotation	55.3 - 70.1	62.7	108.3
	x-Ray	14.6 - 59.4	37	102.15
Sharma [5], 1950	Interferometer		30	103.26

SUMMARY

A detailed description is given of the technique of measuring the coefficients of expansion of crystals of salts by the flotation method.

A float method is proposed for measuring the temperature coefficient β of the density of a liquid, based on the measurement of the difference in flotation temperatures of two floats in the investigated liquid and in a control liquid, for which the true value of β is known.

The coefficients of expansion γ_c for NaCl, KCl, KBr and LiF have been measured close to room temperature. It is shown that the reproducibility of the measured values of γ_c is 0.5-1%. This is in agreement with the estimation of the accuracy of the method made by Konstantinov and Ryskin [1].

The measured values of γ_c are in satisfactory agreement with the results of recent interferometer and x-ray measurements of the coefficients of expansion of the corresponding salts.

LITERATURE CITED

- [1] B. P. Konstantinov and T. Ia. Ryskin, Doklady Akad. Nauk SSSR 108, 455 (1956).
- [2] A. N. Brodskii, Chemistry of Isotopes [In Russian] (Acad. Sci. USSR Press, 1952).
- [3] R. Srinivisan, Indian Inst. Sci. A 232, 37 (1955).
- [4] Adenstedt, Ann. Physik 26, 69 (1936).
- [5] S. Sharma, Proc. Indian Acad. Sci. 32A, 268 (1950).
- [6] H. Fizeau, Ann. Physik (5 Ser.) 132, 292 (1867).
- [7] F. Henglein, Z. Physik Chem. 115, 91 (1925).
- [8] M. Straumanis, A. Levins and K. Karlsons, Z. anorg. u. allgem. Chem. 238, 175 (1938).
- [9] R. Glover, Z. Physik 138, 222 (1954).
- [10] A. Gott, Ann. Physik 41, 520 (1942).
- [11] F. Conneil and H. Martin, Acta Cryst. 4, 75 (1951).

Leningrad Physico-Technical Institute
Academy of Sciences, USSR

Received October 11, 1957

Translation of:- Fizika Tverdogo Tela, 1, (6), 963-969, 1959.

FLOTATION METHOD FOR MEASURING THE COMPRESSIBILITY COEFFICIENTS OF SOLIDS AND LIQUIDS

B. P. Konstantinov, Yu. M. Baikov and G. Ya. Ryskin

Leningrad Physicotechnical Institute, Academy of Sciences, USSR

Compressibility coefficients are usually measured by piezometric [1] or acoustic [2] methods.

The possibility of using a flotation method for density measurements or for compressibility investigations of solids and liquids was indicated in a previous publication [3].

The present paper derives the basic formulae and describes the measurement system and characteristics of a new flotation method for measuring compressibility coefficients.

Derivation of the Formulae for the Compressibility Coefficients of a Liquid

Let the flotation pressures of two floats at the same temperature in the liquid investigated be represented by p_1 and p_2 .

It is clear that:

$$\left. \begin{aligned} \rho_1(p_2) &= \rho_1(p_1) \\ \rho_2(p_2) &= \rho_2(p_1) \\ \rho_2(p_2) &= \rho_2(p_1) [1 + \beta_f (p_2 - p_1)] \end{aligned} \right\} \quad (1)$$

where $\rho_1(p_1)$, $\rho_2(p_1)$ and $\rho_1(p_2)$ are the densities of the first and second floats and of the liquid at a pressure p_1 ; and $\rho_2(p_2)$ and $\rho_1(p_2)$ are the densities of the second float and the same liquid at a pressure of p_2 ; β_f is the compressibility coefficient of the float.

From (1), the variation in the liquid density with variation in pressure from p_1 to p_2 is equal to:

$$\rho_1(p_2) - \rho_1(p_1) = \rho_2(p_2) - \rho_2(p_1) + \rho_2(p_1) \beta_f (p_2 - p_1). \quad (2)$$

The mean compressibility coefficient of the liquid over the range from p_1 to p_2 is:

$$\beta_l = \frac{1}{\rho_1(p_1)} \frac{\rho_1(p_2) - \rho_1(p_1)}{p_2 - p_1}, \quad (3)$$

and from (2) and (3) taking into account (1) we get:

$$\beta_l = \frac{\Delta \rho_f}{\rho_1(p_1)} \frac{1}{p_2 - p_1} + \beta_f \frac{\rho_2(p_1)}{\rho_1(p_1)} \quad (4)$$

where $\Delta\rho_f = \rho_2(p_1) - \rho_1(p_1)$.

Since under experimental conditions $\rho_2(p_1)/\rho_1(p_1)$ is very close to unity, it is possible to use the simpler formula:

$$\beta_1 = \frac{\Delta\rho_f}{\rho_1(p_1)} \frac{1}{p_2 - p_1} + \gamma_f. \quad (5)$$

The value of $\Delta\rho_f/\rho_1(p_1)$ can be determined by a flotation method. For this purpose it is sufficient to measure the flotation temperature of both floats T_1 and T_2 in a liquid with a known coefficient of thermal expansion $\bar{\gamma}_l$ at constant pressure and to know the coefficient of expansion of the float γ_f .

$$\frac{\Delta\rho_f}{\rho_1(p_1)} = (\gamma_1 - \gamma_f)(T_1 - T_2). \quad (6)$$

From (5) and (6) we get:

$$\beta_1 = (\gamma_1 - \gamma_f) \frac{T_1 - T_2}{p_2 - p_1} + \beta_f. \quad (7)$$

Thus, in order to measure the compressibility coefficient of the liquid it is sufficient to measure the flotation temperature of the two floats at constant pressure, and the flotation pressure of the same floats at constant temperature.

Let us examine the accuracy of this method. The relative error $\delta(\bar{\beta}_l - \bar{\beta}_f)$ in measuring $(\bar{\beta}_l - \bar{\beta}_f)$ is $\delta(\bar{\beta}_l - \bar{\beta}_f) = \delta(\gamma_1 - \gamma_f) + \delta(T_1 - T_2) + \delta(p_2 - p_1)$.

Normally $\bar{\gamma}_f \ll \bar{\gamma}_l$. Consequently $\delta(\bar{\gamma}_l - \bar{\gamma}_f) \approx \delta\bar{\gamma}_l$. With average pycnometer measurement accuracy it is possible to estimate the value of $\delta\bar{\gamma}_l$ as 0.1%. Assuming, on the basis of our experimental data and data contained in the literature, that the errors in determining the flotation temperature and pressure amount to $\pm 0.002^\circ\text{C}$ [4] and ± 0.01 atm, respectively, we obtain a maximum measurement error of approximately 2% if $p_2 - p_1 = 5$ atm. ($\bar{\beta}_l = 50 \times 10^{-6} \text{ atm}^{-1}$, $\bar{\gamma}_l = 10^{-3} \text{ degree}^{-1}$). The error decreases as the pressure interval increases.

The compressibility of the liquid can be determined with a single float. If at pressures p_1 and p_2 the flotation temperatures are T_1 and T_2 , respectively, we get:

$$\rho(p_1, T_1) = \rho_1(p_1, T_1), \quad (8)$$

$$\rho(p_2, T_2) = \rho_1(p_2, T_2). \quad (9)$$

From (8) and (9):

$$\rho_1(p_2, T_2) - \rho_1(p_1, T_1) = \rho(p_2, T_2) - \rho(p_1, T_1). \quad (10)$$

Expressing the density variations of the liquid and the float by corresponding compressibility and thermal expansion coefficients, we obtain from (10):

$$\begin{aligned} \rho_1(p_1, T_1) [\bar{\beta}_l(p_2 - p_1) - \gamma_1(T_2 - T_1)] &= \\ = \rho(p_1, T_1) [\beta_f(p_2 - p_1) - \gamma_f(T_2 - T_1)]. \end{aligned} \quad (11)$$

From (8) and (11) we get:

$$\bar{\beta}_l = (\gamma_1 - \gamma_f) \frac{T_2 - T_1}{p_2 - p_1} + \beta_f \quad (12)$$

Consequently, when using a single float, it is sufficient to measure the flotation pressure of the float p_2 and p_1 at two temperatures T_2 and T_1 . The accuracy of this method determined in the same way as that of the two-float method described earlier, indicates a maximum relative error for an individual measurement of $(\bar{\beta}_l - \bar{\beta}_f)$ of 2% if the pressure difference amounts to 5 atm.

If, in the stead of the two-float method, the single-float method is used to determine compressibility coefficients for the case of large pressure intervals, it becomes necessary to know the pressure dependence of $\bar{\gamma}_l$.

Derivation of the Formulae for the Compressibility Coefficients of Solids

The single-float method described above can be used to investigate the compressibility of solids. If the compressibility coefficient of the liquid $\bar{\beta}_l$ is known, then the compressibility of the float material can be determined from (12). The error involved is high, amounting to 40-50% if $\bar{\beta}_f < 5 \times 10^{-6} \text{ atm}^{-1}$.

A more accurate flotation determination of the compressibility of solids can be obtained by measuring the difference in the density of the crystal and float of known compressibility coefficient in two flotation liquids.

Indicating the flotation pressures of the float and crystal in the first liquid by p_{1f} and p_{1c} , the densities at these pressures by $\rho_f(p_{1f})$ and $\rho_c(p_{1c})$, and the corresponding values in the second liquid by p_{2f} , p_{2c} and $\rho_f(p_{2f})$, $\rho_c(p_{2c})$ respectively, we obtain:

$$\left. \begin{aligned} \rho_c(p_{1c}) &= \rho_{1l}(p_{1c}), \\ \rho_f(p_{1f}) &= \rho_{1l}(p_{1f}), \end{aligned} \right\} \quad (13)$$

$$\left. \begin{aligned} \rho_c(p_{2c}) &= \rho_{2l}(p_{2c}), \\ \rho_f(p_{2f}) &= \rho_{2l}(p_{2f}). \end{aligned} \right\} \quad (14)$$

From (13) and (14) we get:

$$\begin{aligned} & [\rho_c(p_{2c}) - \rho_c(p_{1c})] - [\rho_f(p_{2f}) - \rho_f(p_{1f})] = \\ & = [\rho_{2l}(p_{2c}) - \rho_{2l}(p_{2f})] - [\rho_{1l}(p_{1c}) - \rho_{1l}(p_{1f})]. \end{aligned} \quad (15)$$

From (3) and (15) we get:

$$\bar{\beta}_c = \frac{\bar{\beta}_{2l}(p_{2c} - p_{2f}) - \bar{\beta}_{1l}(p_{1c} - p_{1f}) + \beta_f(p_{2f} - p_{1f})}{p_{2c} - p_{1c}}, \quad (16)$$

where $\bar{\beta}_c$ is the mean compressibility coefficient of the crystal over the range p_{1c} to p_{2c} ; $\bar{\beta}_f$ is the mean compressibility coefficient of the float over the range p_{1f} to p_{2f} ; $\bar{\beta}_{1l}$ and $\bar{\beta}_{2l}$ are the mean compressibility coefficients of the flotation liquids over the intervals p_{1c} to p_{1f} and p_{2c} to p_{2f} , respectively.

If the first liquid or the float is selected in such a way that $p_{1c} = p_{1f}$, the second term in the numerator on the right-hand side of (16) becomes zero and it is no longer necessary to determine $\bar{\beta}_{1l}$. In this case $\bar{\beta}_c$ is given by the simpler expression:

$$\bar{\beta}_c = (\bar{\beta}_{2l} - \beta_f) \frac{p_{2c} - p_{2f}}{p_{2c} - p_{1c}} + \beta_f. \quad (17)$$

Thus, in order to determine the compressibility coefficient of the crystal, it is necessary to select a pressure $p_{1c} = p_{1f}$ and a temperature value at which the densities of the float crystal are equal, and then measure the flotation pressures of the float and crystal at the same temperature in another liquid.

The maximum relative error for an individual measurement of $(\bar{\beta}_c - \bar{\beta}_f)$ is:

$$\delta(\bar{\beta}_c - \bar{\beta}_f) = \delta(\bar{\beta}_{21} - \bar{\beta}_f) + \delta(p_{1c} - p_{1f}) + \delta(p_{2c} - p_{2f}) \quad (18)$$

The relative error in determining $(\bar{\beta}_{21} - \bar{\beta}_f)$ does not exceed 2%. The accuracy in measuring the flotation pressures is ± 0.01 atm; consequently $\delta(p_{2c} - p_{2f}) = 0.5\%$ if $p_{2c} - p_{2f} = 5$ atm. However, the error $\delta(p_{2c} - p_{2f})$ may be considerably larger. Thus, in the case of flotation of a NaCl crystal ($\bar{\beta}_c = 4.2 \times 10^{-6} \text{ atm}^{-1}$) and a quartz float ($\bar{\beta}_f = 2.6 \times 10^{-6} \text{ atm}^{-1}$) in ethylene bromide ($\bar{\beta}_{21} = 62.7 \times 10^{-6} \text{ atm}^{-1}$) we get from (17):

$$p_{2c} - p_{2f} = \frac{\bar{\beta}_c - \bar{\beta}_f}{\bar{\beta}_{21} - \bar{\beta}_f} (p_{1c} - p_{1f}) = 0.13 \text{ atmos.}$$

For the given flotation measurement accuracy $\delta(p_{2c} - p_{2f}) = 15\%$ and consequently $\delta(\bar{\beta}_c - \bar{\beta}_f) = 18\%$.

This does not take into account errors in the determination of the pressure and temperature at which the float and crystal densities are equal. In this case, the error $\delta(\bar{\beta}_c - \bar{\beta}_f)$ for NaCl would increase to 25%.

Increase in the difference $p_{2c} - p_{2f}$ to 20-30 atm would apparently decrease the error by 3 to 4 times.

Measurement Technique

The preparation of the flotation liquids and floats and the growth of the crystals were carried out as described in [4].

The experimental measurement system is shown in Fig. 1.

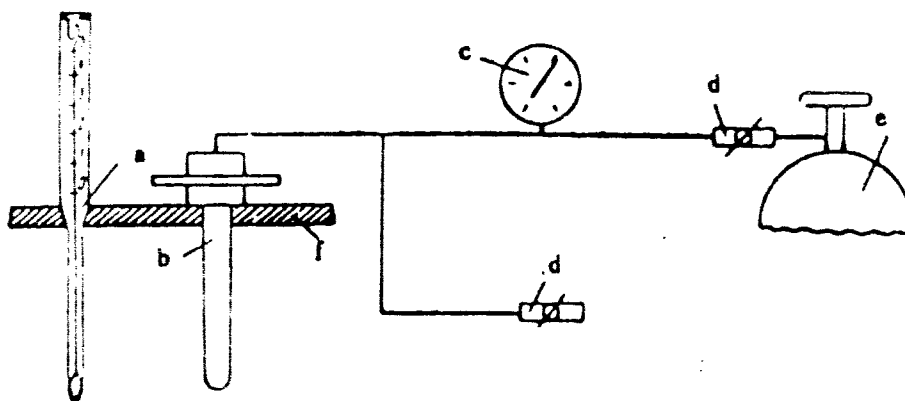

Fig. 1. Experimental arrangement. a) Beckmann thermometer; b) flotation test tube; c) manometer; d) reducer; e) compressed gas cylinder; f) thermostat cover.

The thermostat temperature could be measured with an accuracy of 0.001°C by means of the Beckmann thermometer a graduated in 0.01°C , using a MIR microscope giving sevenfold magnification. The pressure in the flotation tube was produced by means of compressed nitrogen fed from the gas cylinder f, via the reducer d, and was measured by a standard spring operated manometer c, grade 0.2 with an upper limit of 6 kg/cm^2 . The reducer g served to relieve the pressure in the system.

Figure 2 shows the test tube and brass cap used for measuring the flotation pressure.* The test tube contains a small glass rod, the lower end of which is located 3 cm above the bottom of the tube but considerably below the level of the liquid in the tube. As a result any density variations arising in the surface layer of the liquid (e.g., due to the solubility of the gas) do not reach the lower level at which the float and crystal are located. This fact was established by special tests which showed that under constant pressure the flotation temperature remained unaltered for a considerable period of time (exceeding 8 hours).

*This construction of a test tube and brass cap was previously used by B. P. Konstantinov and Yu. B. Kesel'man for a similar purpose.

The flotation pressure p_{fl} was determined by finding the minimum pressure interval within the limits of which the float (crystal) changes its direction of motion. The midpoint of this interval was taken as the flotation pressure. It is clear that the error in determining p_{fl} does not amount to more than half of this interval. In our experiments the error amounted to ± 0.02 atm. In order to increase the accuracy in determining the flotation pressure we measured the rate of movement of the float for a number of pressure values p close to p_{fl} . These experiments showed that between the limits $p - p_{fl} = \pm 0.5$ atm., the rate of movement was dependent on p . Using this relationship it was possible to determine the flotation pressure with an error of less than 0.01 atm.

Measurement Results

The flotation method was used to measure the compressibility coefficients of ethylene bromide, bromoform and NaCl crystals over the pressure range from 1 to 6 kg/cm² at temperatures of 26.4 and 61.6°C for the first, 25.9 and 69.2°C for the second and 26.4°C for the NaCl.

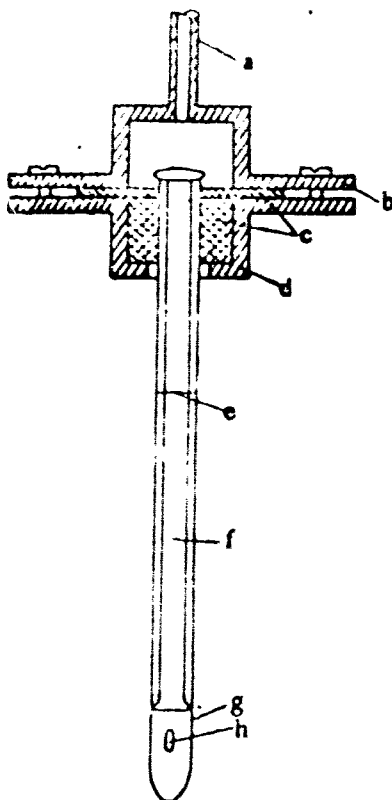

Fig. 2. Flotation test tube a) connecting tube; b) upper brass attachment; c) rubber gasket; d) lower brass attachment; e) liquid level; f) glass rod; g) test tube of length 27 cm, diameter 1 cm; h) float (crystal).

TABLE 1

Results of Compressibility Measurements for Ethylene Bromide at 26.4°C*

Exptl. No.	$T_1 - T_2, ^\circ\text{C}$	$p_2 - p_1, \frac{\text{kg}}{\text{cm}^2}$	$\beta_l \cdot 10^6, \frac{\text{cm}^3}{\text{kg}}$
1	0.257	4.18	61.9
2	0.259	4.18	62.3
3	0.254	4.14	61.7
4	0.258	4.16	62.4
5	0.263	4.24	62.4
6	0.265	4.24	62.8
7	0.270	4.34	62.6
8	0.268	4.34	62.1
9	0.267	4.24	63.3
10	0.279	4.44	63.2
11	0.349	5.60	62.7
12	0.279	4.01	62.9
13	0.349	5.00	63.1
14	0.302	4.75	63.9
15	0.327	5.21	63.1
		Mean	62.7

* In experiments Nos. 1-11, 14 and 15 $\bar{\gamma}_l = 965 \times 10^{-6} \text{ degree}^{-1}$, $\bar{\gamma}_f = 1.3 \times 10^{-6} \text{ degree}^{-1}$; in experiments Nos. 12 and 13 $\bar{\gamma}_l = 965 \times 10^{-6} \text{ degree}^{-1}$, $\bar{\gamma}_f = 121 \times 10^{-6} \text{ degree}^{-1}$, $\bar{\beta}_f = 4.2 \times 10^{-6} \text{ cm}^3/\text{kg}$ (float - 1.01 crystal).

The compressibility of the liquids was measured by means of a single-float method. In calculating $\bar{\beta}_l$ from (12) we used the values of $\bar{\gamma}_l$ given in [4] and tabulated values of $\bar{\beta}_f$ and $\bar{\gamma}_f$ for fused quartz: $\bar{\beta}_f = 2.6 \times 10^{-6} \text{ atm}^{-1}$ [5] and $\bar{\gamma}_f = 1.3 \times 10^{-6} \text{ degree}^{-1}$ [6].

Air films or bubbles attached to the floats had no significant effect on the values of $\bar{\beta}_f$ and $\bar{\gamma}_f$ obtained for the floats, since their relative volume was small (less than 3%).

The accuracy and reproducibility of the method are indicated by the measurement data given in Table 1 for ethylene bromide at 26.4°C and in Table 2 for sodium chloride at 26.4°C. The data show that the maximum

TABLE 2

Results of Compressibility Measurements for NaCl Crystals at 26.4°C*

Exptl. No.	$\bar{\rho}_c - \rho_{1c}$, kg/cm ²	$\rho_{2c} - \rho_{1c}$, kg/cm ²	$(\bar{\rho}_c - \bar{\rho}_f) \cdot 10^6$, cm ² /kg	$\bar{\rho}_f \cdot 10^6$, cm ² /kg
1	4.93	0.13	1.6	4.2
2	4.39	0.19	1.4	4.0
3	3.97	0.12	1.8	4.4
4	4.24	0.09	1.3	3.9
5	4.29	0.10	1.4	4.0
6	5.18	0.14	1.6	4.2
7	5.41	0.20	2.2	4.8
8	5.44	0.17	1.9	4.5
9	4.53	0.08	1.1	3.7
10	4.67	0.08	1.0	3.6
11	4.96	0.12	1.5	4.1
12	5.21	0.11	1.3	3.9
13	5.20	0.17	2.0	4.6
14	4.77	0.13	1.6	4.2
15	4.71	0.16	2.1	4.7
16	4.95	0.12	1.5	4.1
17	5.00	0.15	1.8	4.4
18	4.90	0.12	1.5	4.1
19	4.89	0.10	1.2	3.8
20	4.88	0.11	1.3	3.9
21	4.94	0.13	1.5	4.2
	Mean		1.6	4.2

* $\bar{\beta}_{2l} = 62.7 \times 10^{-6}$ cm²/kg, $\bar{\beta}_f = 2.6 \times 10^{-6}$ cm²/kg. Experiments 1 to 5 and 6 to 12 were carried out with crystals, pulled from the melt; experiments Nos. 13 to 21 with a rock salt crystal.

TABLE 3

Compressibility Coefficients for Ethylene Bromide, Bromoform and Sodium Chloride

Material	Measurement method and literature reference	$\beta \cdot 10^6$, cm ² /kg	T°C
Ethylene bromide	Piezometric method* [7]	61	26.4
	Contact piezometer** [8]	61.6	26.4
	Acoustic method [9]	53.1	26.4
	Flotation method	62.7 ± 0.1	26.4
	Piezometric method* [7]	76	61.6
	Acoustic method [9]	77.7	61.6
Bromoform	Flotation	78.0 ± 0.2	61.6
	Contact piezometer** [8]	57.6	25.9
	Acoustic method [9]	56.6	25.9
	Flotation method	56.0 ± 0.2	25.9
NaCl crystals	Flotation method	72.2 ± 0.2	69.2
	Two-dimensional compression** [11]	4.26	30
	Acoustic method** [12]	4.31	25
	Contact piezometer** [10]	4.2	25
	Flotation method	4.20 ± 0.04	26.4

* Measurements within the limits 1-5.25 atm.

** Extrapolated to the pressure value $p = 0$.

deviation from the arithmetic mean of the complete series of measurements is approximately 2% for ethylene bromide, which is in agreement with the previous estimate of the error in determining liquid compressibility. In the case of NaCl, assuming the true value of $\bar{\beta}_f$ to be known, the maximum deviation from the mean value of $\bar{\beta}_c$ is approximately 15%. Examination of the data obtained indicates that the probable measurement error for liquids is 0.2% and for NaCl crystals 1%.

The results of all the measurements are summarized in Table 3, which for the purpose of comparison gives the isothermal compressibility coefficients of the same compounds measured by other methods. The latter are reduced to the same temperatures at which comparison was made with respect to the temperature dependence obtained in references [4, 9].

The data given in Tables 1 to 3 show that the flotation method is particularly suitable for investigating the compressibility of liquids. The accuracy achieved with this method is comparable with that of the acoustic method, which is generally estimated as 0.25-0.5%. The simplicity of the apparatus and of the experimental arrangement may be mentioned as advantages of the flotation method.

In conclusion it may be said that the flotation method appears very suitable for investigating the compressibility of polymers for which, as a rule, β is somewhat in excess of 10^{-5} atm⁻¹. In this respect it is interesting to note that the density and thermal expansion coefficient of the polymers can be measured simultaneously with the compressibility.

RESULTS

1. A new flotation method for measuring the compressibility coefficients of solids and liquids has been developed.
2. Measurements were made of the compressibility coefficients of ethylene bromide, bromoform and crystalline NaCl.
3. It is shown that the results obtained agree within 1-2% with the results obtained with the same compounds by other methods of measurement.
4. The suitability of the flotation method for investigating the compressibility of liquids and polymers has been demonstrated.

LITERATURE CITED

- [1] P. W. Bridgman, *High-Pressure Physics (1935): Recent Research in the Sphere of High Pressure Physics (1948)*.
- [2] I. G. Mikhailov, *Propagation of Ultrasonic Waves in Liquids [in Russian] (GTTI, 1949)*.
- [3] B. P. Konstantinov and G. Ya. Ryskin, *Doklady Akad. Nauk SSSR* 108, 455 (1956).
- [4] B. P. Konstantinov, Z. N. Efremova and G. Ya. Ryskin, *J. Tech. Phys. (USSR)* 28, 8, 1740 (1958).*
- [5] P. W. Bridgman, *Proc. Am. Acad. Art. Sci.* 75, 65-87 (1948).
- [6] *International Critical Tables (I. C. T.)*
- [7] de Heen, *Bulletin de la classe des sciences academie royale de Belgique* 9, 550 (1885) (see also I. C. T. 3, 35).
- [8] T. W. Richards, *J. Am. Chem. Soc.* 26, 339 (1904).
- [9] R. T. Lagemann, D. R. McMillan, Jr. and W. E. Woolf, *J. Chem. Phys.* 17, 4 (1948).
- [10] T. W. Richards, *J. Am. Chem. Soc.* 31, 158 (1909).
- [11] P. W. Bridgman, *Proc. Am. Acad. Art. Sci.* 64, 33 (1929); P. W. Bridgman, *Rev. Mod. Phys.* 18, 1 (1946).
- [12] D. Lazarus, *Phys. Rev.* 76, 552 (1949).

Received June 4, 1958

* [Soviet Physics - Technical Physics, p. 1604].

"Le probleme du liquide de reference
pour la détermination de la masse
volumique de l'eau de mer"

par

M. Menaché, Office de la Recherche
Scientifique et Technique Outre-Mer,
Paris, France.

1. PREAMBULE - Pour l'établissement d'une équation d'état de l'eau de mer, la masse volumique de l'eau de mer devrait être connue, en fonction des paramètres dont elle dépend, à la précision de 1.10^{-3} kg/m³.

Des déterminations absolues de la masse volumique de l'eau de mer à la précision considérée ne semblent pas aujourd'hui à notre portée. Nous aurions en effet, pour ce faire, le choix entre deux méthodes de mesures:

1. la mesure géométrique directe d'un volume: celui du pycnomètre qui contiendrait l'eau de mer, ou du flotteur qui y serait immergé. Une telle mesure, parfaitement possible aujourd'hui, serait extrêmement coûteuse;

2. le recours à un liquide de référence dont la masse volumique soit connue à une précision d'au moins 1.10^{-3} kg/m³, pour toutes les valeurs des paramètres dont elle est fonction.

Un tel liquide n'existe malheureusement pas encore. L'eau pure, qui a été utilisée jusqu'ici à cette fin, se révèle être un corps hétérogène, dont la masse volumique est connue avec une précision insuffisante. En effet:

1) La valeur de référence 999,972 kg/m³ qui a représenté jusqu'ici la masse volumique de l'eau privée d'air à 4°C et sous une atmosphère normale, ne se rapporte pas à une composition isotopique bien définie et, de ce fait, se trouve entachée d'une incertitude de plusieurs unités de la 3ème décimale.

2) Les lois de variation de la masse volumique de l'eau en fonction de la température et de la concentration en gaz atmosphériques dissous sont insuffisamment connues. En particulier, la loi de variation avec la température est connue avec une incertitude qui devient sensible aux températures supérieures à 15°C, et qui croît avec la température.

L'"eau pure" ne convient donc pas comme liquide de référence, à la précision qui nous intéresse.

Il faut espérer qu'un jour proche, une nouvelle étude systématique de la masse volumique de l'eau serait entreprise; ou qu'il serait possible de construire un pycnomètre ou un flotteur dont le volume, dans des conditions physiques bien précisées, serait mesuré par voie géométrique avec une précision suffisante.

En attendant, la difficulté pourrait être tournée si nous pouvions disposer pour faire fonction de liquide de référence, d'un liquide pouvant être obtenu et conservé à l'état de parfaite homogénéité et de grande pureté, et dont la composition isotopique reste invariable. Ce liquide serait utilisé, pour les déterminations de masse volumique, dans des conditions physiques toujours les mêmes. Nous prendrions par exemple une eau pure,

de composition isotopique parfaitement définie et stable, exempte de gaz dissous, à 4°C et sous une atmosphère normale. La masse volumique d'un tel liquide serait une constante qu'on pourrait espérer déterminer plus tard, mais qui, en attendant, permettrait d'obtenir pour l'eau de mer les valeurs de la masse volumique à un facteur constant près, très voisin de 1.

2. CHOIX DU LIQUIDE DE REFERENCE - L'eau obtenue par la méthode de COX et McCARTNEY (1965) à partir de l'eau de mer semble répondre parfaitement aux conditions requises d'un "liquide de référence". Sa composition isotopique serait pratiquement identique à celle de l'eau de mer, laquelle est remarquablement constante. Si l'identité de la composition isotopique des deux liquides est bien établie, l'eau de COX et McCARTNEY aurait, dans des conditions physiques données, une masse volumique stable à $\pm 2.10^{-4} \text{kg/m}^3$ près.

Il faudrait, toutefois, bien s'assurer de l'identité de la composition isotopique de cette eau et de l'eau de mer. Cette identité a été vérifiée, à notre connaissance, par une seule série de déterminations, ce qui nous paraît insuffisant.

Nous pensons nécessaire:

- 1) que plusieurs lots d'eau pure soient préparés à des dates différentes par la méthode de COX et McCARTNEY;
- 2) que des échantillons de chaque lot soient soumis dans plusieurs laboratoires différents, à des analyses isotopiques portant sur l'oxygène-18 et le deutérium. Des déterminations analogues devraient être faites par les mêmes laboratoires sur l'eau de mer à partir de laquelle a été préparé chaque lot d'eau pure.

Il serait en outre avantageux, par une modification appropriée de la méthode de COX et McCARTNEY, d'obtenir et d'enfermer dans les ampoules scellées, de l'eau privée de gaz atmosphériques dissous. Le liquide de référence devrait en effet, à notre avis, être défini comme exempt de gaz dissous pour les deux raisons suivantes:

- 1) les déterminations de masse volumique sur des liquides contenant une quantité appréciable de gaz dissous sont malaisées et incertaines, à cause de la formation sur les parois du pycnomètre ou sur le flotteur, de bulles de gaz qui faussent les résultats et qu'il est difficile de bien éliminer;
- 2) la loi de variation de la masse volumique en fonction de sa concentration en gaz dissous est peu précise, et pourrait, dans certaines circonstances, donner lieu à une erreur de l'ordre de $\pm 1.10^{-3} \text{kg/m}^3$.

La proposition des auteurs, de procéder en cas de nécessité à une nouvelle distillation sous vide pour obtenir de l'eau exempte de gaz dissous, ne saurait être retenue, une pareille distillation entraînant inévitablement une modification de la composition isotopique du liquide.

Le choix de l'eau de COX et McCARTNEY aurait, en outre, l'avantage de permettre la préparation du liquide de référence quelques jours seulement avant son utilisation pour des déterminations de masse volumique. On éviterait ainsi les longues conservations en ampoules scellées susceptibles, à la longue, d'altérer la pureté du liquide.

Le moment venu, lorsqu'il sera possible de procéder à la détermination absolue de la masse volumique du liquide de référence, ce liquide pourrait être fraîchement préparé en vue de cette détermination fondamentale.

Le liquide de référence pourrait donc être défini comme étant l'eau de COX et McCARTNEY (composition isotopique analogue à celle du S.M.O.W.), exempte de gaz atmosphériques dissous, à la pression d'une atmosphère normale et à une température $t^{\circ}\text{C}$ à choisir. Toutes les déterminations qui seraient faites sur ce liquide de référence devraient l'être dans des conditions aussi voisines que possible de celles figurant dans la définition.

Quelle valeur choisir pour la température t ?

La température du minimum de dilatation thermique de l'eau, 4°C , paraît la plus avantageuse à deux points de vue:

1) elle permettrait de se montrer moins exigeant sur la constance et l'homogénéité de la température de l'eau au moment des déterminations. Des variations de quelques dixièmes de deg C au sein du liquide seraient sans conséquence sur la précision des résultats;

2) la loi de variation de la masse volumique en fonction de la concentration en gaz atmosphériques dissous est mieux connue au voisinage de cette température, ayant fait l'objet d'une étude particulière de CHAPPUIS (1910), étude qui a porté sur l'intervalle de température de 5 à 8°C . En cas de nécessité, les corrections correspondantes pourraient être faites avec un risque d'erreur plus faible.

La température 0°C ou celle du point triple de l'eau ($+0,01^{\circ}\text{C}$) seraient également avantageuses à cause de leur facilité de production et de maintien durant de longues périodes de temps.

Il est toutefois difficile d'opérer à des températures très inférieures à l'ambiante, et de nombreux laboratoires préfèrent travailler à des températures voisines de 20°C . Le choix pour l'eau de référence d'une température égale ou supérieure à 20°C , s'il facilite ainsi le travail pratique, présente à la fois un avantage et un inconvénient.

L'avantage est qu'à ces températures, l'influence des gaz dissous devient, d'après MAREK (1891), négligeable.

L'inconvénient, et il est très sérieux, est qu'à ces températures, une variation de 1°C de la température de l'eau entraîne pour cette eau

une modification de la masse volumique de l'ordre de $2 \cdot 10^{-1} \text{ kg/m}^3$. La constance et l'homogénéité de la température du liquide devraient, dans ces conditions, être assurées, durant les mesures, à quelques millièmes de degré Celsius près.

BIBLIOGRAPHIE

- CHAPPUIS, P. (1910) - Etude de l'influence de l'air dissous sur la densité de l'eau. - Trav. et Mém. du B.I.P.M., XIV, 1-63.
- COX, R.A., McCARTNEY, M.J. (1965) - Distilled Water for Relative Density Standard. - N.I.O. Internal Report No. C5.
- MAREK, W. (1891) - Ausdehnung des Wassers. - Annal. der Phys. und Chem., XLIV, 171-172.

Members of the Joint Panel on Oceanographic Tables and Standards

(as at 1 January 1968)

			<u>Appointed by</u>
Chairman :	Mr. F. Hermann	Danmarks Fiskeri-og Havundersøgelser Charlottenlund Slot, Charlottenlund, Denmark.	ICES
	Prof. O. Saelen	Universitet i Oslo Oceanografisk Institut Blindern, Oslo Norway	ICES
	Dr. G.N. Ivanov-Frantzkevich	Institute of Oceanology Academy of Sciences of the USSR 1 Sadovaya Street Lublino, Moscow Zh-387 U.S.S.R.	UNESCO
	Dr. W.P. Fofonoff	Woods Hole Oceanographic Institution Woods Hole, Massachusetts U.S.A.	IAPSO
	Prof. Dr. W. Kroeber	Institut für Angewandte Physik Neue Universität, Haus 34 Kiel 23 Federal Republic of Germany	IAPSO
	Dr. F.H. Fisher	Scripps Institution of Oceanography San Diego, California 92152 U.S.A.	SCOR
	Dr. F. Culkin	National Institute of Oceanography Wormley, Godalming Surrey, England	ICES
	Dr. K. Grasshoff	Institut für Meereskunde der Universität Kiel Niemannsweg 11 23 Kiel Federal Republic of Germany	SCOR
	Mr. M. Menache	Institut Océanographique Laboratoire d'Océanographie physique 195 rue St. Jacques Paris 5, France	UNESCO

Former Members

Dr. R.A. Cox

National Institute of Oceanography
Wormley, Godalming
Surrey, England

Prof. Dr. G.
Dietrich

Institut für Meereskunde
Niemannsweg 11
23 Kiel
Federal Republic of Germany

Prof. D. Carritt

Dept. of Geology and Geophysics
Massachusetts Institute of Technology
Cambridge 39, Massachusetts
U.S.A.

Dr. Y. Miyake

Meteorological Research Institute
Mabashi, Suginami-ku
Tokyo, Japan

Resolution No. 11

The International Association of Physical Oceanography,

Considering that the techniques for precise estimation of dissolved salts in sea water have been significantly improved during recent years, particularly by the introduction of conductivity methods;

Noting the careful experimental work establishing the relationship between conductivity ratio, chlorinity and temperature carried out under the leadership of the late Dr. R.A. Cox;

Further noting the review and endorsement of this work by the Joint ICES/IAPO/SCOR/UNESCO Panel of Experts on Oceanographic Tables and Standards, and the publication by UNESCO of the International Oceanographic Tables, based on this work;

Resolves to endorse the International Oceanographic Tables, and the definition of salinity and the relation between salinity and chlorinity contained in the introduction to Table 1a therein, and to recommend their use by oceanographers.

**Unesco technical papers
in marine science
no. 14**

**Fifth report of the Joint Panel on
Oceanographic Tables and Standards**

**Kiel,
10 - 12 December 1969
sponsored by
Unesco, ICES, SCOR, IAPO**

Unesco

FIFTH REPORT OF THE JOINT PANEL
ON OCEANOGRAPHIC TABLES AND STANDARDS

Kiel, 10-12 December 1969

jointly sponsored by the
United Nations Educational, Scientific and Cultural Organization
International Council for the Exploration of the Sea
Scientific Committee on Oceanic Research
International Association of Physical Oceanography

The scientific views expressed here are those of experts participating in the work of the Panel and not necessarily those of Unesco or other sponsoring organizations.

The members of the Joint Panel of Experts on Oceanographic Tables and Standards (Annex III) were invited to attend a meeting in Kiel from 10 to 12 December 1969. The meeting was held at the Institute for Applied Physics of the University.

The members present were:

Mr. Frede Hermann (Chairman)	}	ICES
Mr. Odd Saelen		
Mr. Fred Culkin		
Dr. N.P. Fofenoff	}	IAPSCO
Prof. W. Kroebel		
Dr. K. Grasshoff	}	SCOR
Dr. Frederick H. Fisher		
Mr. M. Menaché	{	Unesco

The Soviet member, Mr. G.N. Ivanoff-Frantzkevich, was unable to attend the meeting.

The observers present were:

Prof. W. Wooster	}	SCOR
Dr. G. Giermann		Unesco
Dr. K. Kremling		I.f.M. Kiel

Prof. Kroebel welcomed the Panel to his institute, and the Chairman then opened the meeting. The agenda as proposed by the Chairman was adopted by the Panel as follows:

1. Adoption of the agenda.
2. Election of the Panel's Chairman.
3. Information on the progress of work:
 - (a) refraction index measurements;
 - (b) oxygen solubility tables;
 - (c) specific gravity of sea water;
 - (d) isotopic composition of distilled water;
 - (e) thermal expansion of sea water;
 - (f) conductivity of sea water under pressure;

The members of the Joint Panel of Experts on Oceanographic Tables and Standards (Annex III) were invited to attend a meeting in Kiel from 10 to 12 December 1969. The meeting was held at the Institute for Applied Physics of the University.

The members present were:

Mr. Frede Hermann (Chairman)	}	ICES
Mr. Odd Saelen		
Mr. Fred Culkin		
Dr. N.P. Fofenoff	}	IAPSCO
Prof. W. Kroebel		
Dr. K. Grasshoff	}	SCOR
Dr. Frederick H. Fisher		
Mr. M. Menaché	{	Unesco

The Soviet member, Mr. G.N. Ivanoff-Frantzkevich, was unable to attend the meeting.

The observers present were:

Prof. W. Wooster	}	SCOR
Dr. G. Giermann		Unesco
Dr. K. Kremling		I.f.M. Kiel

Prof. Kroebel welcomed the Panel to his institute, and the Chairman then opened the meeting. The agenda as proposed by the Chairman was adopted by the Panel as follows:

1. Adoption of the agenda.
2. Election of the Panel's Chairman.
3. Information on the progress of work:
 - (a) refraction index measurements;
 - (b) oxygen solubility tables;
 - (c) specific gravity of sea water;
 - (d) isotopic composition of distilled water;
 - (e) thermal expansion of sea water;
 - (f) conductivity of sea water under pressure;

- (g) measurements of sound velocity as function of pressure, temperature and salinity;
- (h) effect on conductivity of changes of composition of sea water.

4. Plans for further laboratory work.
5. Schedule of publishing new instalments to the International Tables.
6. Other matters

Item 2 of the agenda was postponed until 12 December.

Item 3 of the agenda

(a) Dr. Culkin referred to the work of Dr. J.S.M. Rusby. The measurements have been finished, the results published (Deep Sea Res. 1967, 14, 427 - 39) and the tables have been included in the Unesco Oceanographic Tables. The question of confirming these measurements was discussed but the Panel could not nominate anybody to perform the expensive measurements with the same precision as Dr. Rusby. With the publication of the tables, the task of the Panel with respect to the refractive index measurements is fulfilled.

(b) According to the resolution of the Panel's meeting in Bern the ICES Sub-Committee for Chemical Analysis of Sea Water was asked to recommend further steps with respect to the oxygen solubility tables. The ICES group recommended in 1967 the smoothing equation of E.J. Green as the basis for new oxygen saturation tables. In the meantime, new independent measurements of the oxygen solubility in sea water had been made by Carpenter and by J.P. Riley. The two new sets of measurements agreed excellently between each other but disagreed to a certain extent from Green's measurements.

In February 1969 a meeting of the recent originators of oxygen saturation values and others concerned with the question was held in Ft. Lauderdale, Florida. The meeting was sponsored by SCOR. The participants were Prof. D.E. Carritt, Prof. Bruce Benson, Dr. E.J. Green, Dr. J.L. Carpenter, Dr. Joris Gieskes, Prof. J.P. Riley, Dr. K. Grasshoff.

As a result of this meeting it was found that the raw data - after some necessary corrections had been applied to Green's measurements - agreed very well and that no significant differences could be found in spite of the fact that completely different techniques have been applied. It was decided that each originator should take all raw data and apply his technique of smoothing and interpolation. The exp. values which are obviously out of the range by more than ± 0.03 ml/l should be rejected and a new smoothing should be made on the basis of the remaining data.

These calculations should be submitted to the Chairman of the meeting not later than fall 1969.

The participants did not feel that new measurements could improve the reliability of the existing data considerably.

Unfortunately the submission of the recalculated saturation values was delayed so that at the time of the meeting no comparison of the different treatments was possible.

In the meantime, R. Weiss from SCRIPPS Institute of Oceanography developed a simple equation for the smoothing of the experimental oxygen saturation data of Carpenter and Riley. This equation has a sound thermodynamical basis and is derived from the Vant'Hoff equation for the dependence of the Bunsen solubility coefficient from the temperature and from the Setchenof equation for the salinity dependence.

This equation has the form:

$$\ln C = A_1 + A_2 \frac{100}{T} + A_3 \ln \left(\frac{T}{100} \right) + A_4 \frac{T}{100} + S \text{‰} (B_1 + B_2 \frac{T}{100} + B_3 \frac{T^2}{10^4})$$

and gives a mean standard deviation from the experimental data of ± 0.018 ml/l resu. ± 0.016 ml/l, depending on the source of the data used in the calculation.

The panel felt that this equation is the best available at present and should be used for the calculation of the new saturation tables.

It was decided that a copy of the preliminary paper of R. Weiss should be sent to the participants of the Ft. Lauderdale meeting for comments. Replies were expected by the end of January 1970. It would thus be possible to calculate the new tables before April 1970 and forward them to Unesco in May.

(c) Dr. Culkin gave a final report on the measurements of the specific gravity of sea water and the relationships to salinity and temperature. These measurements form the basis of the new tables to be published by Unesco as part of the Oceanographic Tables. The format of the tables was discussed. The Panel felt that the form of the U.S. Navy tables for the conversion of salinity and temperature into sigma-t is the most convenient. Moreover, it was discussed whether the basic determinations of the N.I.O should possibly be confirmed by an independent institution but it seemed unlikely that the Panel could nominate anybody able to do this with comparable accuracy. Dr. Kremling mentioned in this connexion that some comparisons which he performed with the new instrument for the determination of specific gravity gave equal results. This instrument allows determinations of the specific gravity with a precision of ± 3 in the third decimal of sigma-t. One determination takes only about 10 minutes. The principle is based on the measurement of the Eigenfrequency of a glass capillary filled with the sample. Before the final edition of the Unesco tables it was recommended to check the silicate content of the reference water. Attention should be paid to the results of the Soviet Institutes on the specific gravity - salinity - temperature relation. Mr. Crease - now head of the British Oceanographic Data Centre - should be approached by Dr. Culkin for calculation and interpolation of the new tables in co-operation with Dr. Fofonoff and Dr. Fisher.

According to a suggestion of Dr. Menaché the new Temperature Scale should be taken into consideration in this connexion. The Chairman expressed the gratitude of the Panel to Dr. Culkin and his colleagues for their excellent work.

The Panel discussed in this connexion the need for comparison of actual measurements of the specific gravity of random selected water samples from all parts of the world ocean and the sigma-t values as calculated from the temperature and the conductometrically determined salinity. Such measurements seemed to be feasible now with the new precision instrument available at the I.f.M. Kiel. The Panel recommended to give Dr. K. Kremling all necessary support to carry out such determinations. Dr. Kremling will approach certain institutes in order to arrange for the provision of samples. He was also asked by the Panel to perform some independent cross-checks on samples from the N.I.O.

(d) Dr. Menaché presented his report on the measurements of the isotopic composition of the reference water distilled according to the N.I.O. procedure from West Mediterranean water from about 2,000 m. The results of the measurements of the samples as supplied by the N.I.O. and by the I.f.M. show that there is no significant deviation of the isotopic composition of the original water and the distillate in either institute. The distillation procedure therefore can be recommended as a standard procedure for a reference water for the determination of the specific gravity. In this connexion the adoption of the new temperature scale was again brought to the attention of the Panel. The Panel asked the new Chairman to submit a short note on this matter to some of the major journals in marine science. The Panel recommends strongly that all calibration certificates etc. should state the use of the new temperature scale. The Chairman expressed to Dr. Menaché the sincere thanks of the Panel for his work. In this connexion the question of the determination of the absolute density of water was raised again. The discussions resulted in a resolution which was adopted by the Panel (Annex I).

(e) The members of the Panel reported on measurements of the thermal expansion of sea water. The Chairman read a letter from Dr. Ivanoff-Frantzkevich giving a progress report on the Soviet measurements of thermal expansion. The measurements will be completed by the middle of 1970. Dr. Fofonoff reported on work being carried out at the Woods Hole Oceanographic Institution by Bradshaw and Schleicher at 30.5, 35.0, 39.5 ‰ S at pressures between 1 and 1,000 bars.

The design of further experiments was discussed, especially in connexion with the measurements of the absolute density of pure water.

(f) The Panel discussed the need for new independent measurements of the pressure dependence of conductivity. The number of in situ pressure - conductivity - temperature - instruments is rapidly increasing. Apart from the experiments started at the Institute of Applied Physics in Kiel no laboratory could be nominated by the members of the Panel which is at present engaged in conductivity pressure measurements. The Chairman recommended that the members of the Panel should investigate whether and where such experiments are being performed or planned. In this connexion, it was discussed that there is also an urgent demand for the extension of the temperature correction values of the relative conductivity below the range as published in the International Oceanographic Tables. Especially the low range (below 12 degrees centigrade) is of special interest because of the fact that most of the in situ conductivity measurements are made at low temperatures. At present, it is impossible to convert the conductivity values measured at low temperatures into conductivities at 15°C, as printed

in the tables. Dr. Fofonoff developed a system of ratios replacing the ratio $R(t,p,S)/R(15,0,35)$. In situ conductivity instruments measure the ratio $\frac{\lambda(T,S,P)}{\lambda(15,35,0)}$.

T,S,P indicate electrical conductivity, temperature, salinity and pressure respectively. In order to convert these measurements to salinities it is necessary to know the function $f(T,S,P) = \frac{\lambda(T,S,P)}{\lambda(15,35,0)}$.

This ratio can be split into a number of ratios as follows:

$$\frac{\lambda(T,S,P)}{\lambda(15,35,0)} = \frac{\lambda(T,S,P)}{\lambda(T,S,0)} \cdot \frac{\lambda(T,S,0)}{\lambda(15,S,0)} \cdot \frac{\lambda(15,S,0)}{\lambda(15,35,0)}$$

In this equation the last ratio is R_{15} , which is tabulated against salinity in the Unesco International Tables, but measurements of the second ratio have not been made.

In order to calculate salinities from the measured ratio $\frac{\lambda(T,S,P)}{\lambda(15,35,0)}$ and measured temperature and pressure it is necessary to measure the ratio $\frac{\lambda(T,S,0)}{\lambda(T,35,0)}$ at temperature below 12°C or to measure the ratio $\frac{\lambda(T,S,0)}{\lambda(15,S,0)}$. The intense discussion resulted in a second recommendation (Annex I).

(g) Prof. Kroebel presented a progress report on the measurements of sound velocity in sea water as a function of salinity, temperature and pressure. A new instrument for precision determination is being developed at his institute which permits a level of precision in sound velocity measurement not known hitherto. Once the fundamental relationships are known, the sound velocity could be used for the determination of, e.g. pressure or density. The Panel had the opportunity to visit Prof. Kroebel's institute and his outstanding instrumentation and experimental set-ups for the determination of the fundamental relationships as mentioned above. The Panel is convinced of the usefulness of Prof. Kroebel's efforts and was very impressed by this demonstration. It was decided by the panel to give Prof. Kroebel all possible support. The Chairman will express the feelings of the Panel in a letter to Prof. Kroebel.

(h) Dr. Fisher presented a summary of the progress of work with respect to the equation of state of sea water. His evaluations were followed by a lively discussion.*

Dr. Kremling presented his investigations on the influence of changes of the ionic composition of sea water of lower salinities and the impact on conductivity. Previous papers of Park and Grasshoff deal especially with the effect of the state of the carbonate system on conductivity. The presentation was followed by an intense discussion. It is the feeling of the Panel that such changes should not be neglected. A verification of the combined effects of sampling, storage and changes in the ionic composition is needed. The laboratory experiments show clearly that the third decimal of the salinity is influenced and that the accuracy of the third decimal of the salinity as obtained by means

(*) Dr. Fisher's presentation is reproduced in Annex II.

of conductivity measurements is doubtful. The difference between accuracy and precision ought to be clearly understood by all users of a conductivity instrument. The best way of checking the accuracy would be to measure the density of samples taken on a routine basis with the new densitometer. Only by such measurements could the value of the third decimal be stated.

In order to check how changes in the carbon dioxide system affect the routine determination of salinity the Panel proposed that institutions which have the opportunity should make replicate determinations on a number of samples of conductivity ratio, density, C1‰ and pH at different time intervals after collection of the sample.

(i) Plans for further laboratory work had already been discussed in connexion with the sub-items of Point 3 of the agenda. The discussions led to the two recommendations of the Panel.

(j) The calculations of the new sigma-t tables should be made as soon as independent checks have been made by Dr. Kremling. The tables and nomographs should be ready for submission to Unesco by the end of 1970. The oxygen saturation tables should be ready for submission in May 1970. It was decided after a thorough discussion that the tables should have the arguments cm^3/dm^3 , Salinity, Temperature. The spacing should be in full units of salinity, and two-tenths of a degree in temperature. To allow a computation of tables in other units, e.g. ml (S,T,P) per kilogramme of water, or micromoles or microgramatoms per litre, the complete set of coefficients and the form of the equations will be published in the preface of the tables.

As it is confirmed by the redeterminations of the specific gravity that the new values do not deviate significantly from the values as published in the Knudsen Hydrographic Tables corresponding to the second decimal in chlorinity, the Panel felt that the density values from the Knudsen Hydrographic Tables are sufficient for the computation of a conversion table salinity into chlorosity at 20°C. Dr. Grasshoff was asked to compile such a conversion table with suitable spacing of the arguments. This conversion table should then be published as an annex to the Unesco Hydrographic Tables, as decided already at the Bern Meeting of the Panel.

Item 2 of the agenda:

The Panel elected Dr. Grasshoff as the new Chairman.

It was decided that the Panel should meet again when new investigations and measurements of relationship as mentioned under items (e), (f), (h) are performed and further additions to the Unesco Hydrographic Tables could be provided.

The Chairman closed the meeting at noon on 12 December 1969, with thanks to the host, Prof. Kroebel.

ANNEX I

RECOMMENDATION 1969, NO. 1

The Joint Panel on Oceanographic Tables and Standards determined that knowledge of the absolute density of sea water as a function of temperature and salinity is necessary to an accuracy of one part per million. Such precision cannot be obtained without acknowledgement of density of pure water to at least the same accuracy in order to use pure water as a reference for the sea water measurements. With the adoption of the new International Practical Temperature Scale in 1968 (Metrologia, 1969, V (2), pp. 35-44), in which the triple point of pure water is taken to be of water having the isotopic composition of ocean water. It is recommended that measurements of the following properties be made at a pressure of one normal atmosphere of degassed water of known isotopic composition, preferably as close as possible to that specified above.

1. Absolute density at 4°C and preferably at at least two other temperatures 0° and 20°C.
2. Thermal expansion to an accuracy sufficient to calculate density to the required accuracy from 0° to 40°C.

The Panel recommends that the measurements be made at least at two different laboratories, such as Bureau International des Poids et Mesures, National Bureau of Standards, National Physical Laboratory.

Considering that, at temperatures superior to 16°C, the density of pure water is now known only with an insufficient precision, it is recommended that, at the time of future determinations of density of sea water, the calibration with pure water is made at 4 or 0°C solely, the thermic dilatation of the sinker (or pycnometer), if it is not known, being able to be determined on a sample of same material, interferometrically.

The Panel hopes that, if necessary, funds can be obtained to ensure that this work can be accomplished.

The Panel asks all great international oceanographic organisms to endorse this Recommendation.

ANNEX II

Analytic Equation of State for Water and Sea Water

F.H. Fisher,
Robert Bruce Williams and O.E. Dial, Jr.

University of California, San Diego
Marine Physical Laboratory
of the
Scripps Institution of Oceanography

The following is a brief summary of the results of work reported at the meeting of the Joint Panel on Tables and Oceanographic Standards in Kiel, December 1970. This work will be presented for publication in more detail at a later date, probably in the Journal of Geophysical Research.

The equation used is the Tumlirz equation used by Eckart ^{1/} in his paper on this subject

$$V = V_{\infty} + \frac{\lambda}{P_0 + P} \quad (1)$$

where V is the specific volume (cc/gm), P the pressure (bars) and V_{∞} , λ , and P_0 are temperature dependent parameters. This equation fits the pure water PV data of Kell and Whalley ^{2/} (K&W) to a precision with the standard deviation of approximately 10 PPM over the temperature range of 0 to 100°. A total of 20 terms appear in the three parameters V_{∞} , λ and P (Table I).

In attempting to fit Eq. (1) to the sea water data of Wilson and Bradley ^{3/}, (W&B), the most extensive set of experimental data from a single laboratory, we found that P_0 , λ and V_{∞} displayed an erratic

dependence on salinity. When λ was constrained to be the value derived from the pure water data of Kell and Whalley, it was found that P_0 and V_∞ displayed a linear dependence on salinity. Finally, the equation used to fit the sea-water data is that shown in Equation (2)

$$V = V_\infty - K_1 S + \frac{\lambda}{P_0 + K_2 S + P} \quad (2)$$

where λ , V_∞ and P_0 are those values used to fit the pure water data. K_1 displays a quadratic temperature dependence and K_2 a linear one (Table I).

Use of Bradshaw and Schleiher's ^{4/} (B&S) data on thermal expansion has been incorporated in our results in the coefficient K_1 . It appears from the B&S data that the W&B data is less reliable at low temperatures.

It should be noted that the pure water equation has a density maximum at 4.00°C. Use has been made of the atmospheric pressure data discussed by Kell ^{5/} in addition to the PV data of K&W.

The density maximum for sea water shows a greater salinity dependence; that is, the cross-over of the freezing point and the density maximum occurs at a lower salinity than stated in the text books, in this case at ~22% instead of ~25%.

This equation, FWD for Fisher, Williams and Dial, then requires 20 terms for the 0-150° pure water data and only five additional terms for sea water. A truncated equation for pure water will be examined to see if the number of parameters for pure water can be reduced in order

to represent only the data between 0° and 40°.

Table II shows the fit of the FWD equation to the W&B data.

Table III summarizes results of various investigators for the thermal expansion coefficient of sea water shown in the W&B technical report along with our results.

Table IV in an analogous manner summarizes the specific volume results along with ours and those calculated by us from Li's results.

Similarly, Table V summarizes the compressibility results.

In Table VI we compare our results for thermal expansion ($\partial V/\partial T$) against those of B&S as a function of temperature, salinity and pressure. At 0° we find the greatest disagreement with their results.

In Table VII we do see, however, that changes in specific volumes from -2° to +2° calculated by the FWD equation compare very favorably with the results of B&S. In this case we are comparing our values from our equation against their raw data.

Values of the adiabatic gradient calculated from the FWD equation for $S=35\%$ were slightly lower than those reported by Fofonoff 6/, for example, 4% at 2° and 400 bars and 7% at 2° and 1,000 bars.

REFERENCES

1. C. Eckart, Am. Jour. Sci., 256, 225 (1958).
2. G.S. Kell and E. Whalley, Proc. Roy. Soc., 258, 565 (1965).
3. W. Wilson and D. Bradley, NOLTR 66-103, U.S. Naval Ordnance Laboratory, White Oak, Silver Spring, Maryland (1966).
4. A. Bardshaw and K.E. Schleicher, "Direct Measurement of Thermal Expansion of Sea Water under Pressure", submitted for publication to Deep Sea Research.
5. G.S. Kell, J. Chem. Engr. Data, 12, 66 (1967).
6. N.P. Fofonoff, The Sea, Vol. 1, 3-30 (1962), N.M. Hill, editor, Interscience Publishers, New York.

TABLE I

TUMLIRZ EQUATION FOR PURE WATER AND SEA WATER

$$V = V_{\infty} - K_1 S + \frac{\lambda}{P_0 + K_2 S + P}$$

$$\lambda = 1788.316 + 21.55053 * T - 0.4695911 * T^2 + 3.096363 \times 10^{-3} T^3 - .7341182 \times 10^{-5} * T^4$$

$$P_0 = 5918.499 + 58.05267 * T - 1.1253317 * T^2 + 6.6123869 \times 10^{-3} * T^3 - 1.4661625 \times 10^{-5} * T^4$$

$$V_{\infty} = .6980547 - .7435626 * 10^{-3} * T + .3704258 \times 10^{-4} * T^2 - .6315724 \times 10^{-6} * T$$

$$+ .9829576 \times 10^{-8} * T^4 - .1197269 \times 10^{-9} * T^5 + .1005461 \times 10^{-11} * T^6$$

$$- .5437898 \times 10^{-14} * T^7 + .169946 \times 10^{-16} * T^8 - .2295063 \times 10^{-19} * T^9$$

$$K_1 = 2.679 \times 10^{-4} + 2.02 \times 10^{-6} * T - 6.0 \times 10^{-9} * T^2$$

$$K_2 = 10.874 - 4.1384 * 10^{-2} * T$$

λ bars cc/gm

P, P_0 bars

K_2 bar/o/oo

V_{∞} cc/gm

K_1 cc/gm/o/oo

TABLE II

Standard deviations in parts per million of the fit of the FWD equation to raw specific volume data of Wilson and Bradley vs. temperature and salinity. (Temperature cited is nominal since data were taken at varying temperatures near cited one.) The average of the standard deviations is 107 ppm for all the data.

T S ‰	10.221	20.720	30.881	35.568	40.370
~ 0°	208	175	230	264	156
~ 5°	173	129	212	187	236
~10°	128	51	167	172	45
~15°	102	38	94	134	55
~20°	42	76	44	140	37
~25°	17	60	85	95	62
~30°	17	106	93	47	104
~35°	22	117	55	43	98
~40°	19	154	34	100	161

TABLE III

THERMAL EXPANSION OF SEA WATER (S = 35°/00)
COMPARISON TABLES

T°C	P Bars	Hydrographic Tables x 10 ⁻⁵	Eckart x 10 ⁻⁵	Crease x 10 ⁻⁵	NOL x 10 ⁻⁵	FWD x 10 ⁻⁵
0°	1	5.2	8.0	5.6	7.8	5.76
	200	10.5	13.4	10.6	13.2	10.9
	400	15.4	18.2	15.0	18.0	15.4
	600	19.8	22.5	17.1	22.2	19.3
	800	23.2	26.6	22.6	26.1	22.6
	1000	26.5	29.5	25.6	29.5	25.5
10°	1	16.7	16.2	16.7	16.3	16.6
	200	20.2	19.9	20.1	20.0	20.1
	400	23.3	23.1	23.2	23.3	23.2
	600	26.1	26.0	26.1	26.3	25.9
	800	28.6	28.8	28.6	29.0	28.3
	1000	30.9	30.7	30.8	31.3	30.5
20°	1	25.7	23.8	25.7	24.1	25.6
	200	27.8	26.2	27.7	26.5	27.8
	400	29.8	28.2	29.7	28.6	29.7
	600	31.7	30.0		30.6	31.5
	800	33.5	31.7		32.3	33.1
	1000	35.5	32.9		33.8	34.6
30°	1	33.5	31.3	33.4	31.7	33.4
	200	34.7	32.5	34.6	33.0	34.5
	400	36.1	33.6	35.7	34.2	35.6
	600	37.6	34.4		35.2	36.5
	800	39.3	35.2		36.1	37.5
	1000	41.4	35.8		36.9	38.3
40°	1	41.0	39.4		39.6	40.5
	200	41.8	39.5		40.0	40.7
	400	43.0	39.5		40.2	41.1
	600	44.6	39.5		40.5	41.4
	800	46.9	39.5		40.6	41.7
	1000	49.6	39.5		40.7	42.1

TABLE IV

SPECIFIC VOLUME OF SEA WATER, (S = 35°/00)
COMPARISON TABLES (cm³/gm)

T°C	P Bars	Hydrographic Tables	Eckart	Crease	NOL	FWD
0°	1	.9726	.9726	.9727	.9726	.9725
	200	.9639	.9640	.9640	.9638	.9638
	400	.9557	.9557	.9558	.9556	.9556
	600	.9479	.9480	.9480	.9479	.9479
	800	.9406	.9407	.9407	.9406	.9406
	1000	.9337	.9338	.9338	.9337	.9337
10°	1	.9737	.9736	.9737	.9738	.9736
	200	.9654	.9654	.9654	.9654	.9653
	400	.9575	.9575	.9576	.9576	.9575
	600	.9501	.9502	.9502	.9502	.9500
	800	.9430	.9432	.9432	.9432	.9430
	1000	.9364	.9366	.9365	.9366	.9363
20°	1	.9758	.9757	.9758	.9757	.9757
	200	.9677	.9678	.9678	.9677	.9677
	400	.9601	.9601	.9602	.9601	.9600
	600	.9528	.9530	.9529	.9529	.9528
	800	.9460	.9462	.9461	.9461	.9459
	1000	.9395	.9397	.9394	.9396	.9394
30°	1	.9787	.9784	.9789	.9784	.9786
	200	.9708	.9706	.9709	.9706	.9707
	400	.9632	.9631	.9632	.9631	.9632
	600	.9561	.9560	.9560	.9560	.9560
	800	.9494	.9493	.9491	.9493	.9492
	1000	.9431	.9430	.9424	.9429	.9428
40°	1	.9823	.9819		.9819	.9722
	200	.9745	.9741		.9741	.9744
	400	.9760	.9666		.9667	.9669
	600	.9601	.9596		.9596	.9598
	800	.9535	.9529		.9529	.9530
	1000	.9473	.9466		.9466	.9466

TABLE V

COMPRESSIBILITY OF SEA WATER, $S = 35\text{‰}$ (Bars⁻¹)
COMPARISON TABLES

T°C	P Bars	Hydrographic Tables x 10 ⁻⁶	Eckart x 10 ⁻⁶	Crease x 10 ⁻⁶	NOL x 10 ⁻⁶	FWD x 10 ⁻⁶
0°	1	46.2	46.5	46.4	46.7	46.3
	200	44.0	44.0	44.0	44.1	43.9
	400	41.7	41.7	41.7	41.7	41.7
	600	39.7	39.5	39.6	39.5	39.6
	800	37.8	37.5	37.7	37.5	37.7
	1000	36.2	35.7	35.9	35.7	36.0
10°	1	44.1	44.1	44.1	44.3	44.0
	200	42.0	41.8	41.9	42.0	41.9
	400	39.9	39.7	39.9	39.8	39.9
	600	38.0	37.8	38.1	37.8	38.1
	800	36.4	36.0	36.3	36.0	36.4
	1000	34.9	34.3	34.6	34.3	34.8
20°	1	42.6	42.5	42.7	42.7	42.6
	200	40.6	40.5	40.6	40.5	40.6
	400	38.7	38.5	38.7	38.5	38.8
	600	36.9	36.7		36.7	37.0
	800	35.3	35.0		35.0	35.4
	1000	33.9	33.4		33.4	33.9
30°	1	41.8	41.6	41.9	41.7	41.7
	200	39.8	39.6	39.8	39.7	39.8
	400	37.9	37.8	38.0	37.8	38.1
	600	36.1	36.1		36.0	36.4
	800	34.4	34.4		34.4	34.8
	1000	32.9	32.9		32.8	33.4
40°	1	41.4	41.3		41.2	41.4
	200	39.3	39.3		39.3	39.5
	400	37.2	37.5		37.4	37.7
	600	35.3	35.8		35.7	36.1
	800	33.4	34.3		34.1	34.5
	1000	31.6	32.8		32.6	33.1

TABLE VI

Comparison of values of $\frac{\partial v^w}{\partial T}_{T,P,S}$ in parentheses calculated from FWD equation with those of Bradshaw and Schleicher computed from their comprehensive formula.

$$\text{Unit of } \frac{\partial v^w}{\partial T}_{T,P,S} = 10^{-6} \frac{\text{cm}^3}{\text{g}^\circ\text{C}}$$

S = 30.50°/oo

T°C	0		10		20		30	
P, bars								
1	(43)	39	(154)	154	(246)	246	(325)	324
500	(159)	158	(230)	229	(291)	290	(345)	346
1000	(235)	240	(284)	284	(324)	323	(362)	362

S = 35.00°/oo

T°C	0		10		20		30	
P, bars								
1	(56)	52	(162)	162	(250)	251	(327)	327
500	(166)	166	(234)	234	(293)	293	(346)	347
1000	(238)	244	(285)	286	(325)	325	(361)	363

S = 39.50°/oo

T°C	0		10		20		30	
P, bars								
1	(68)	65	(169)	170	(254)	256	(329)	329
500	(172)	174	(238)	239	(295)	296	(347)	348
1000	(241)	248	(287)	289	(325)	326	(361)	363

TABLE VII

Calculated values from FWD equation vs. B&S observed values for the change in the specific volume of sea water from -2° to +2°. FWD values are listed in parentheses: Units are in 10⁻⁶ cc/gm.

P bars	201.3	401.2	601.0	800.9	1000.8
Salinity o/oo	35.004	35.005	35.004	35.002	35.006
T°C					
-2		(-269) -277.1	(-352) -356.9	(-415) -424.3	(-467) -480.5
-1	(-101) -97.5				
0	(0) 0	(0) 0	(0) 0	(0) 0	(0) 0
+2	(230) 225	(310) 310	(379) 383	(437) 445	(486) 498

ANNEX III

Members of the Joint Panel on Oceanographic Tables and Standards
(as at 1 December 1969)

		<u>Appointed by</u>
Mr. F. Hermann (Chairman)	Danmarks Fiskeri-og Havundersøgelser Charlottenlund Slot, Charlottenlund, Denmark	ICES
Prof. O. Saalen	Universitet i Oslo Oceanografisk Institut Blindern, Oslo Norway	ICES
Dr. G.N. Ivanov-Frantzkevich	Institute of Oceanology Academy of Sciences of the USSR 1 Sadovaya Street Lublino, Moscow Zh-387 USSR	Unesco
Dr. N.P. Fofonoff	Woods Hole Oceanographic Institution Woods Hole, Massachusetts U.S.A.	IAPSO
Prof. Dr. W. Kroebel	Institut für Angewandte Physik Neue Universität, Haus 34 Kiel 23 Federal Republic of Germany	IAPSO
Dr. F.H. Fisher	Scripps Institution of Oceanography San Diego, California 92152 U.S.A.	SCOR
Dr. F. Culkin	National Institute of Oceanography Wormley, Godalming Surrey, England	ICES
Dr. K. Grasshoff (new Chairman from the end of the 5th meeting on)	Institut für Meereskunde der Universität Kiel Niemannsweg 11 23 Kiel Federal Republic of Germany	SCOR
Mr. M. Menaché	Institut Océanographique Laboratoire d'Océanographie physique 195 rue St. Jacques Paris 5, France	Unesco

Former Members

Dr. R.A. Cox

National Institute of Oceanography
Wormley, Godalming
Surrey, England

Prof. Dr. G. Dietrich

Institut für Meereskunde
Niemannsweg 11
23 Kiel
Federal Republic of Germany

Prof. D. Carritt

Department of Geology and Geophysics
Massachusetts Institute of Technology
Cambridge 39, Massachusetts
U.S.A.

Dr. Y. Miyake

Meteorological Research Institute
Mabashi, Suginami-ku
Tokyo, Japan

UNESCO TECHNICAL PAPERS IN MARINE SCIENCE

Titles of numbers which are out of stock

No.		Year	SCOR WG
1	Incorporated with Nos. 4, 8 and 14 in No. 27	1965	WG 10
2	Report of the first meeting of the joint group of experts on photosynthetic radiant energy held at Moscow, 5-9 October 1964. Sponsored by Unesco, SCOR, IAPO	1965	WG 15
3	Report on the intercalibration measurements in Copenhagen, 9-13 June 1965. Organized by ICES	1966	—
4	Incorporated with Nos. 1, 8 and 14 in No. 27	1966	WG 10
5	Report of the second meeting of the joint group of experts on photosynthetic radiant energy held at Kauizawa, 15-19 August 1966. Sponsored by Unesco, SCOR, ICES	1966	WG 15
6	Report of a meeting of the joint group of experts on radiocarbon estimation of primary production held at Copenhagen, 24-26 October 1966. Sponsored by Unesco, SCOR, ICES	1967	WG 20
7	Report of the second meeting of the Committee for the Check-List of the Fishes of the North Eastern Atlantic and of the Mediterranean, London, 20-22 April 1967 Procès-verbal de la 2e réunion du Comité pour le catalogue des poissons du nord-est atlantique et de la Méditerranée, Londres, 20-22 avril 1967	1968	—
8	Incorporated with Nos. 1, 4 and 14 in No. 27	1968	WG 10
10	Guide to the Indian Ocean Biological Centre (IOBC), Cochin (India), by the Unesco Curator 1967-1969 (Dr. J. Tranter)	1969	—
12	Check-List of the Fishes of the North-Eastern Atlantic and of the Mediterranean (report of the third meeting of the Committee, Hamburg, 8-11 April 1969)	1969	—
14	Incorporated with Nos. 1, 4 and 8 in No. 27	1970	WG 10